

TRADITIONS® WOOD SHUTTERS

TABLE OF CONTENTS

FEATURES

The Graber Wood Story	2
Wood Characteristics	3

OPTIONS

Shutter Styles	4-5
Product Illustrations	6
Louver Options	7
Tilt Options: Hide-a-Tilt™, Split Tilt	8
Panel Overlap Styles	8
Double Mouse Hole	9
Shutter Color: Color Options, Hinge Colors, Additional Color Information and Custom Color Match Process	9-10
Panel Configurations – Standard Shutters	11
Size Considerations: Minimum and Maximum Width Order Sizes by Panel Configuration: 2½", 3½" & 4½" Louvers	12
Frame Type Decision Tree	13
Measuring for Standard Shutters	14
Measuring Divider Rail or Split Tilt Location, Divider Rail Requirements, Measuring T-Post Locations	15
Frame Product Detail	16-18
Specifications: Deductions for Frame Allowances	19
Specifications: Frame Configurations	20
Specifications: Installation Hardware	21

SPECIALTY STYLES

Café Shutters	22
Sunburst Arch Without Frame	23
Sunburst Arch With Frame	24
Sunburst Arch Installation Methods	25
Arched Panel Shutter and Angled Top Panel	26-28
French Door, Cut-Out and Minimum/Maximum French Door Sizes	28-30
Bypass Shutters and Valance Options	31-32
Bypass Track System Configuration Options – Only Configurations Available	33
Bypass Shutter – Minimum/Maximum Width Order Sizes by Panel Configuration	33
Bypass Track System – Stackback and Custom Header Width	34
Bi-fold Track System	35
Bi-fold Shutter – Minimum/maximum Width Order Sizes by Panel Configuration	36
Bi-fold Track System Panel Configuration Options	36
Bi-fold Shutters – Stackback and Valance Options	37
Side Light	38
Bay Windows	39-40
Corner Windows	41-42

GENERAL INFORMATION

Definitions	43
Warranty and Care Instructions	44

PRICE CHARTS AND OPTION PRICING

Wood Shutter Pricing	45
--------------------------------	----

Features

THE GRABER WOOD STORY

Quality of Wood Defines a Shutter's Quality

We use only 100% North American hardwood in the construction of our wood shutters because of its light weight, consistent color, hardness, structural stability and attractive grain.

Sound Forestry Techniques

We work only with foresters who practice sustainable forest management. Nearly twice as much hardwood grows as is harvested in the U.S. each year. The volume of hardwoods in American forests today is 90% larger than it was 50 years ago.

Preserving Our Natural Resources

Our Springs Window Fashion (SWF) Wood facility in Grayling, Michigan, consumes recycled sawdust and wood shavings, generating the heat required to dry lumber, for a completely self-sufficient manufacturing process. Our Reynosa, Mexico, fabrication and finishing facility is 99.7% pollution-free, above any U.S. standard.

SWF Wood Facility in Grayling, Michigan

We have control over the quality of wood used – we control the process from green lumber to finished shutters. Hardwoods used in crafting Graber wood shutters are kiln-dried and molded at our SWF Wood facility. The wood is dried slowly to strict wood shutter specifications because structural change can occur when moisture is removed. Molding and sanding operations provide the highest quality surface, free of defects.

SWF Wood Fabrication and Finishing in Reynosa, Mexico

At our state-of-the-art finishing plant in Reynosa, Mexico, components are carefully sorted prior to fabrication for color uniformity and wood characteristics. We sort wood as an end user, rather than as a finishing vendor, taking out defects in a climate-controlled building. Each shutter is handmade by craftsmen to your client's custom needs. To finish the shutter, we use only high quality paints and stains; on-site certified color technicians provide both application and quality control.

What Makes Graber Shutters Different From the Rest?

- Wood shutters are made from 100% North American hardwoods, the premier wood used in the construction of shutters
- SWF wood facilities provide state-of-the-art technologies and processes
- Expanded finish choices with unique staining process that showcases the natural grain of the wood
- An outstanding selection of styles, louvers (including 4½" size), frames and arches
- The best Customer Service team in the industry — trained to answer any questions about Graber shutters
- Limited Lifetime Warranty (see Warranty section)

Features

WOOD CHARACTERISTICS

Wood used to manufacture wood shutters has many natural characteristics that make it truly unique; no two pieces of hardwood are alike. The following are all natural characteristics of wood, and we do not consider them to be defects:

- Grain – The direction, size, and appearance of wood fibers vary greatly depending on where the wood is cut within the tree
- Tiger Striping – Directional change in grain pattern
- Burl – Formed from an irregular growth on the outer edge of the tree
- Bird's Eye – Small area on the surface of the board where fibers are contorted to form circular figures that resemble birds' eyes
- Knots – Vary in size, shape, structure, and color (only solid knots less than $\frac{3}{8}$ " diameter are allowed)
- Mineral Marks – Dark or discolored areas caused by minerals which the tree extracts from the soil; they can be either streaks or stains, usually blackish blue

Natural variations in color and grain effect are inherent in the beauty of wood. These variations are within established industry guidelines and should be expected. In addition, shutters may stain slightly darker or lighter than the samples shown.



Flat Grain



Grain Change



Mineral Marks



Tiger Striping



Burl/Bird's Eye



Knots

Options

SHUTTER STYLES

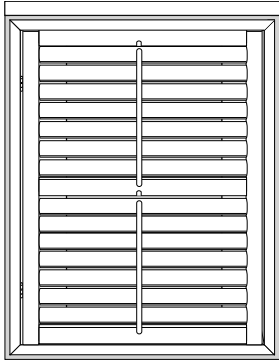

Standard Panel: A rectangular-shaped panel that can be installed using any frame style. Panel covers the entire window opening.

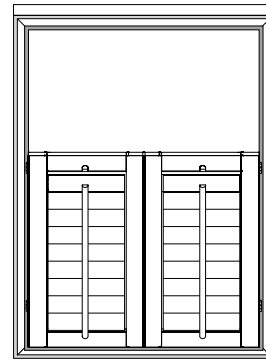

Café: Classic style covers the bottom part of the window, allowing light to enter while protecting your privacy. A good choice for bedrooms or bathrooms.

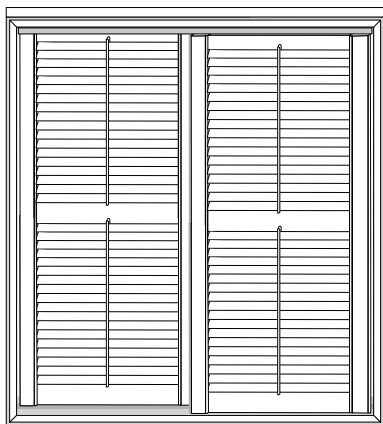

Bypass Track System: Shutter panels slide on a double top track to open and close. The track system can be attached to a frame or mounted directly to a window casing or the ceiling. Ideal for patios or closet doors.



Bi-fold Track System: Two, four or eight panels are hinged together with a top and bottom track. Popular for large windows, patio doors, or sliding glass doors.

Options

SHUTTER STYLES

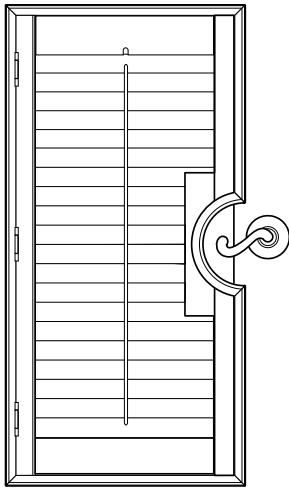

French Doors: Add the beauty of shutters to French Doors. Curved or rectangular cutout options complement contemporary door handles or traditional door knobs.

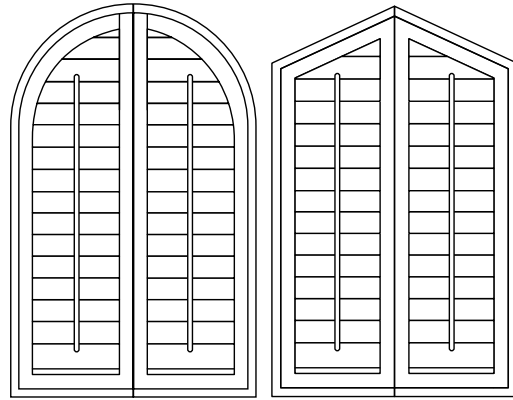

Arched or Angled Top Panels: Provide whole window solutions that fit the rounded shape of full arch windows perfectly. Angled panels accommodate slanted windows. Available in full arch or angle, ½ arch, or ¼ angle.

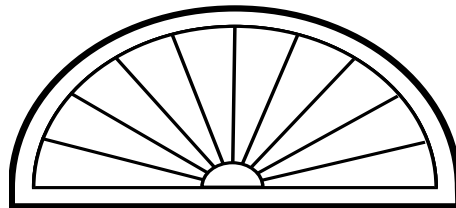

Sunburst Arches: Sunburst patterned louvers cover unique window silhouettes such as eyebrow, elongated and elliptical arches.

Options

PRODUCT ILLUSTRATIONS

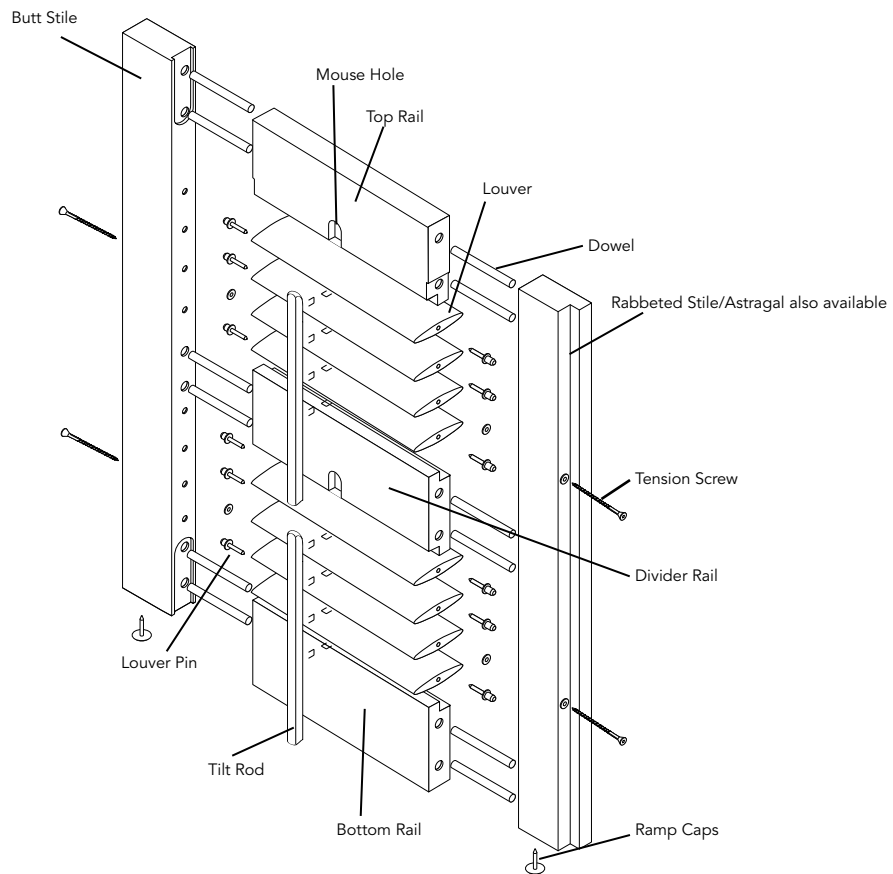
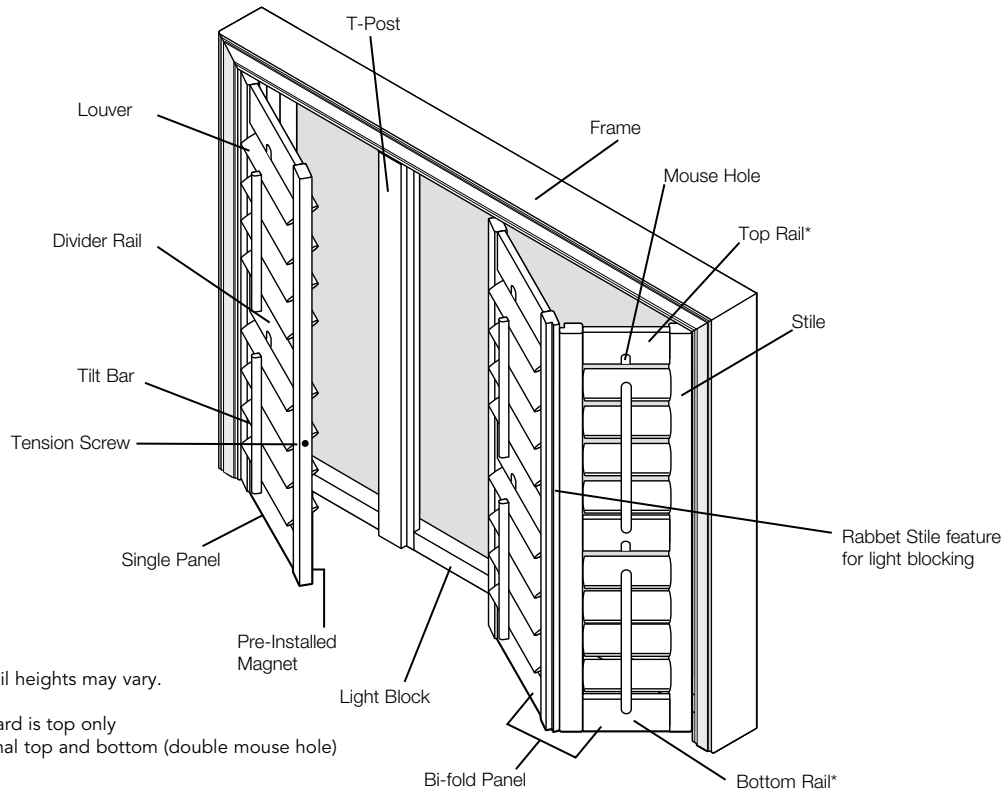

Options

LOUVER OPTIONS

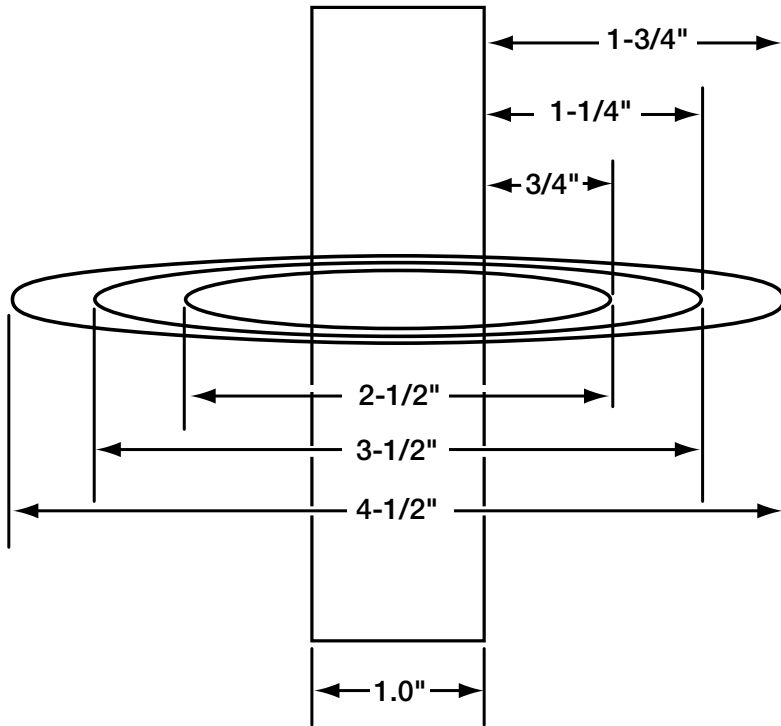

Note: Hide-a-Tilt requires an additional $\frac{3}{8}$ " window clearance

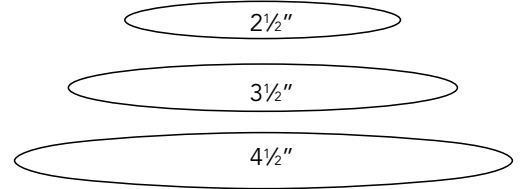

Minimum Clearance Needed From Back Panel Surface		
Louver Size	Standard Tilt	Hide-a-Tilt™
2½"	¾"	1⅛"
3½"	1¼"	1⅝"
4½"	1¾"	2⅛"

2½" Louver

- Traditional in style; most widely used louver size
- Minimal window depth needed
- Shutters are focal point of the room

3½" Louver

- Offers more visibility and light control than 2½" louver
- Design flexibility when working with space around shutter

4½" Louver

- Provides the greatest visibility through the open louvers
- Looks most proportionate in a larger window; view beyond the window becomes more important
- Louvers almost disappear when open

Wood Louver Sizes

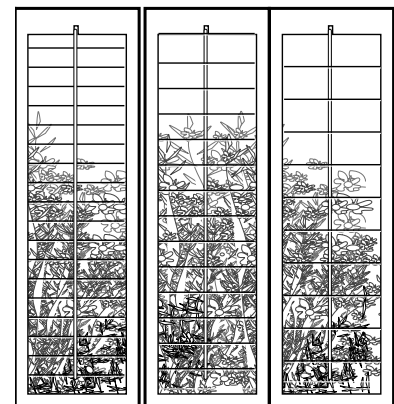

2½"

3½"

4½"

Options

TILT OPTIONS: HIDE-A-TILT™

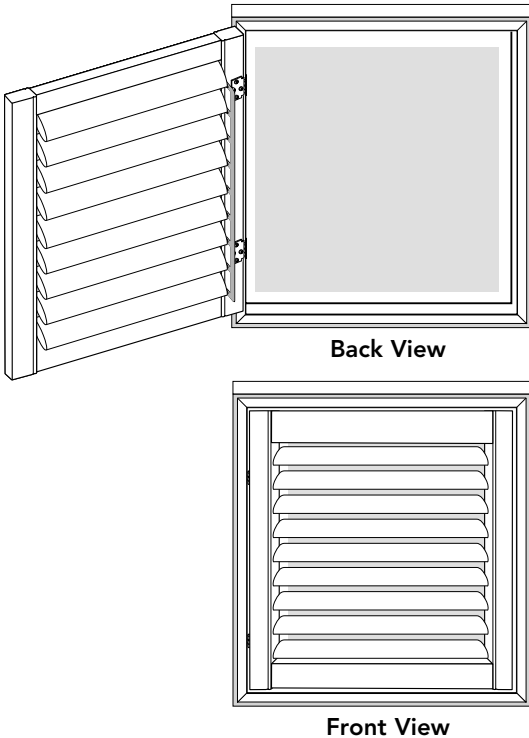

Hide-a-Tilt Option offers the tilt mechanism in the back of the shutter panel, eliminating the traditional tilt bar and creating an unobstructed view, as well as a clean linear appearance. A thin stainless steel tilt bar is attached to the louvers in the rear of the panel. Operation of the shutter is as simple as positioning one louver into position; all of the other louvers will follow.

- **Hide-a-Tilt bar will always be stainless steel color**
- Hide-a-Tilt is mounted on hinge side for standard shutters
- No mouse hole in the panel
- Hide-a-Tilt allows the shutter to be closed in the upward or downward position

TILT OPTIONS: SPLIT TILT

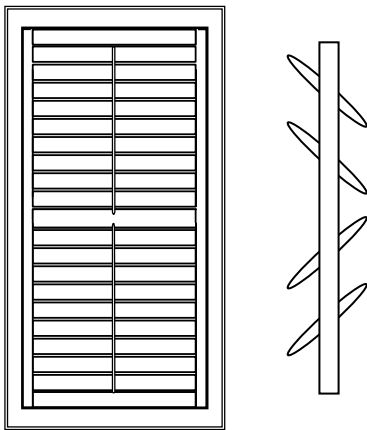

Split Tilt

No divider rail. Splits one large louver set into two individually operated louver sets by cutting the tilt bar.

- All louver sizes
- Can be ordered at desired location
- Split Tilt offered for front tilt bar
- Split Tilt offered on Hide-a-Tilt™

Consideration: Upper and lower louvers cannot be positioned at opposing angles because the edges of the louvers will touch.

PANEL OVERLAP STYLES

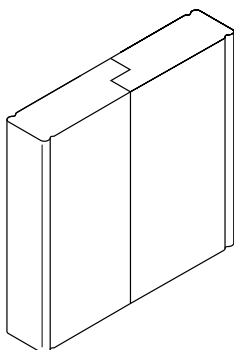

Rabbet Style Panel Overlap

- Factory standard
- Right over left overlap only
- Left over right overlap not available

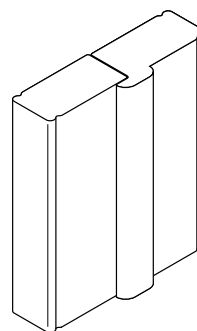

Astragal Style Panel Overlap

- No charge option
- Right over left overlap standard
- Left over right overlap optional
- Astragal used on center
- Astragal will be used between bi-fold panels

Options

DOUBLE MOUSE HOLE

A mouse hole on the rail above and below each louver section allows the louvers to be closed in the upward or downward position.

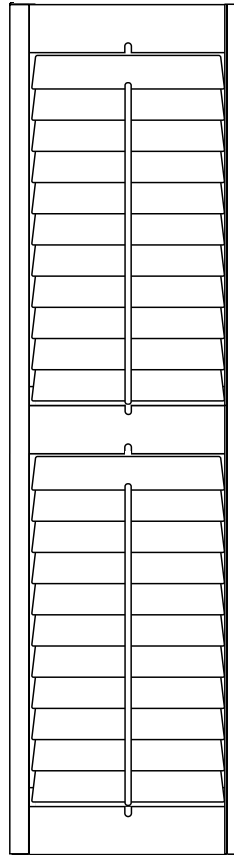
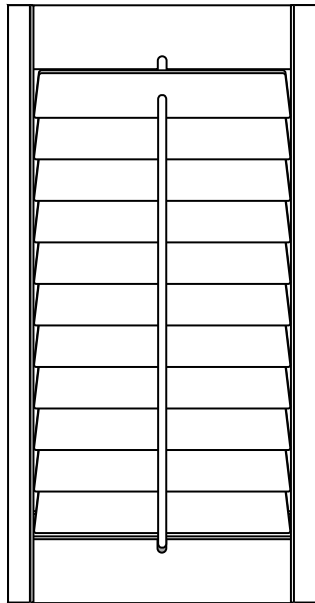

SHUTTER COLOR OPTIONS

Painted Colors

Almond.....	1724
Angora.....	1052
Antique White	1026
Base White	1051
Bone*.....	1024
Crisp White.....	1712
Designer White.....	1055
Dover White	1683
Ivory	1325
Putty	1410
Snowflake	1603
Stark White.....	1869
Stucco.....	1963
Swiss Coffee*.....	1692
Vanilla	1100

Stained Colors

Blackened Raven	1690	Mocha.....	1759
Bridgewood.....	1069	Natural	1007
Cappuccino	1546	Peru	1688
Cherrywood.....	1014	Pinewood.....	1056
Cognac	1465	Raven.....	1919
Colonial Oak.....	1911	Sable.....	1565
Dark Cherry	1316	Saddle Brown	1694
Dark Walnut.....	1641	Sienna.....	1685
Espresso	1716	Tawny	1045
Golden Oak.....	1030	Truffle	1054
Honey Maple.....	1013	Walnut	1012
Knotty Pine.....	1515	Wheat.....	1710
Light Pecan.....	1020		

*Colors available but not sampled.

Options

HINGE COLORS

Select the hardware color that best fits your decor:

- White
- Off White
- Antique Brass
- Oil Rubbed Bronze
- Satin Nickel
- Bright Brass

ADDITIONAL COLOR INFORMATION

Due to the nature of manufacturing, colors may vary slightly between dye lots. Please order all shutters for the same room at the same time. Slight variations may also occur between the finished products and the color samples (see the Wood Characteristics section).

All standard colors in Traditions® 2" Wood Blind Collection are available with no additional surcharge. Does not include unique finishes or Traditions Elite colors.

CUSTOM COLOR MATCH PROCESS

1. Complete the Custom Color Match Request Form.
2. Supply Springs Window Fashions with a color sample. For best results, submit a 3" x 3" color sample.
3. Send the form and the sample to:
Springs Window Fashions
8467 Route 405 South
P.O. Box 500
Montgomery, PA 17752
Attn: Shutter Department
4. Strike-off approval is required for all shutter orders.
5. Strike-offs will be sent for approval within 10-14 days of receiving the color sample.
6. Once color approval is received, fabrication of the custom shutters will begin.

Options

PANEL CONFIGURATIONS – STANDARD, ARCH AND ANGLED TOP SHUTTERS

Panel Configurations Must Be Selected From This Chart

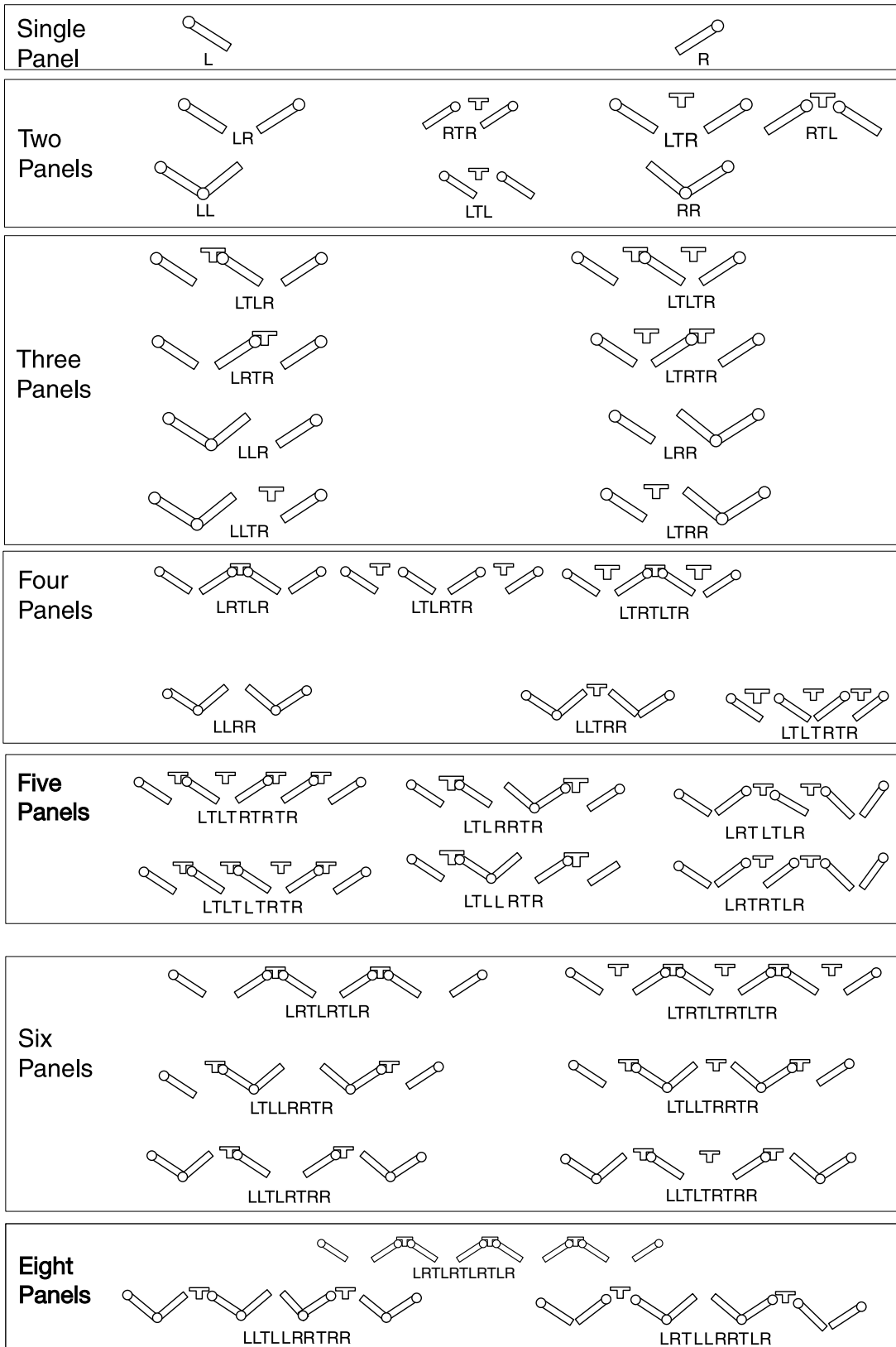

Size Considerations

MINIMUM AND MAXIMUM WIDTH ORDER SIZES BY PANEL CONFIGURATION: 2 1/2", 3 1/2" & 4 1/2" LOUVERS

PANEL CONFIGURATION	Examples of shutter configurations with combinations of panels and T-Posts	DIRECT MOUNT, HANG STRIP, TILT OUT Z-FRAMES		Z-FRAMES		L-FRAMES		NARROW L-FRAME		3" TRADITIONAL DECO FRAME		3 1/2" CURVED DECO FRAMES	
		Order W-O Size		Order W-O Size		Order F-F Size		Order F-F Size		F-F Size		F-F Size	
		Minimum Width	Maximum Width	Minimum Width	Maximum Width	Minimum Width	Maximum Width	Minimum Width	Maximum Width	Minimum Width	Maximum Width	Minimum Width	Maximum Width
1 Panel		9 3/16"	36 3/16"	11"	38"	11 3/16"	38 3/16"	10 1/16"	37 1/16"	13 13/16"	40 13/16"	14 15/16"	41 15/16"
2 Panel		18 1/16"	72 1/16"	19 7/8"	73 7/8"	20 1/16"	74 1/16"	19 9/16"	73 9/16"	22 1/16"	76 1/16"	23 13/16"	77 13/16"
2 Panel, 1 T-Post		19 9/16"	73 9/16"	21 1/16"	75 3/16"	21 3/8"	75 3/8"	20 7/8"	74 7/8"	24"	78"	25 5/8"	79 5/8"
1 Bi-Fold		18 1/16"	52 1/16"	19 7/8"	53 7/8"	20 1/16"	54 1/16"	19 9/16"	53 9/16"	22 1/16"	56 1/16"	23 13/16"	57 13/16"
1 Panel, 1 Bi-Fold		27 1/4"	88 1/4"	29 1/16"	90 1/16"	29 1/4"	90 1/4"	28 3/4"	89 3/4"	31 7/8"	92 7/8"	33"	94"
1 Panel, 1 Bi-Fold, 1 T-Post		28 1/4"	89 1/4"	30 1/16"	91 1/16"	30 1/4"	91 1/4"	29 3/4"	90 3/4"	32 7/8"	93 7/8"	34"	95"
3 Panel, 1 T-Post		28 1/4"	109 1/4"	30 1/16"	111 1/16"	30 1/4"	111 1/4"	29 3/4"	110 3/4"	32 7/8"	113 7/8"	34"	115"
3 Panel, 2 T-Post		29 9/16"	110 9/16"	31 3/8"	112 3/8"	31 9/16"	112 9/16"	31 1/16"	112 1/16"	34 3/16"	115 3/16"	35 5/16"	116 5/16"
2 Bi-Fold		36 5/16"	104 5/16"	38 7/8"	106 7/8"	38 5/16"	106 5/16"	37 13/16"	105 13/16"	40 15/16"	108 15/16"	42 1/16"	110 1/16"
2 Bi-Fold, 1 T-Post		37 1/8"	105 1/8"	38 15/16"	106 15/16"	39 7/8"	147 7/8"	38 5/8"	106 5/8"	41 3/4"	109 3/4"	47 7/8"	110 7/8"
4 Panel, 1 T-Post		37 1/8"	145 1/8"	38 15/16"	146 15/16"	39 7/8"	147 7/8"	38 5/8"	146 5/8"	41 3/4"	149 3/4"	42 7/8"	150 7/8"
4 Panel, 2 T-Post		38 1/16"	146 1/16"	40 1/4"	148 1/4"	40 9/16"	148 9/16"	39 5/16"	147 5/16"	43 1/16"	151 1/16"	44 3/16"	152 3/16"
4 Panel, 3 T-Post		39 3/4"	147 3/4"	41 1/16"	149 1/16"	41 3/4"	149 3/4"	41 1/4"	149 1/4"	44 3/8"	152 3/8"	45 1/2"	153 1/2"
5 Panel, Bi-Fold, 2 T-Post		47 5/8"	162 5/8"	51 1/4"	166 1/4"	51 5/8"	166 5/8"	51 1/8"	166 1/8"	56 7/8"	171 7/8"	51 1/8"	174 7/8"
5 Panel, Bi-Fold, 2 T-Post		47 5/8"	162 5/8"	51 1/4"	166 1/4"	51 5/8"	166 5/8"	51 1/8"	166 1/8"	56 7/8"	171 7/8"	51 1/8"	174 7/8"
5 Panel, 2 T-Post		47 5/16"	182 5/16"	50 15/16"	185 15/16"	51 3/16"	189 3/16"	50 11/16"	188 11/16"	54 13/16"	194 13/16"	59 11/16"	195 11/16"
5 Panel, 4 T-Post		49 15/16"	184 15/16"	53 9/16"	188 9/16"	53 15/16"	188 15/16"	53 7/16"	188 7/16"	57 9/16"	193 13/16"	60 9/16"	195 9/16"
5 Panel, 4 T-Post		49 15/16"	184 15/16"	53 9/16"	188 9/16"	53 15/16"	188 15/16"	53 7/16"	188 7/16"	57 9/16"	193 13/16"	60 9/16"	195 9/16"
6 Panel, 2 Bi-Fold, 2 T-Post		56 3/16"	178 11/16"	58 1/2"	180 1/2"	58 1/16"	180 1/16"	59	181	61 1/16"	183 5/16"	62 1/16"	184 7/16"
6 Panel, 2 T-Post		56 3/16"	218 3/16"	58"	220"	58 3/16"	220 3/16"	57 11/16"	219 11/16"	60 13/16"	222 13/16"	61 5/16"	223 5/16"
6 Panel, 2 Bi-Fold, 3 T-Post		57 1/2"	179 1/2"	59 9/16"	181 5/16"	59 1/2"	181 1/2"	60	181	62 7/8"	184 7/8"	63 3/4"	185 1/4"
6 Panel, 5 T-Post		60 7/8"	222 7/8"	61 15/16"	223 15/16"	62 7/8"	224 7/8"	61 5/8"	233 5/8"	64 3/4"	226 3/4"	65 7/8"	227 7/8"
8 Panel, 2 Bi-Fold, 2 T-Post		73 15/16"	249 15/16"	75 3/4"	251 3/4"	75 15/16"	251 15/16"	75 7/16"	251 7/16"	78 7/16"	254 7/16"	79 11/16"	255 11/16"
8 Panel, 4 Bi-Fold, 2 T-Post		73 15/16"	209 15/16"	75 3/4"	211 3/4"	75 15/16"	211 15/16"	75 7/16"	211 7/16"	78 7/16"	214 7/16"	79 11/16"	215 11/16"
8 Panel, 3 T-Post		75 1/4"	291 1/4"	77 1/16"	293 1/16"	77 1/4"	293 1/4"	76 3/4"	292 3/4"	79 7/8"	295 7/8"	81"	297"

Windows larger than 105" may require splicing for the frame.

Options

FRAME TYPE DECISION TREE

Review window and the area around the window. Choose from the options below.

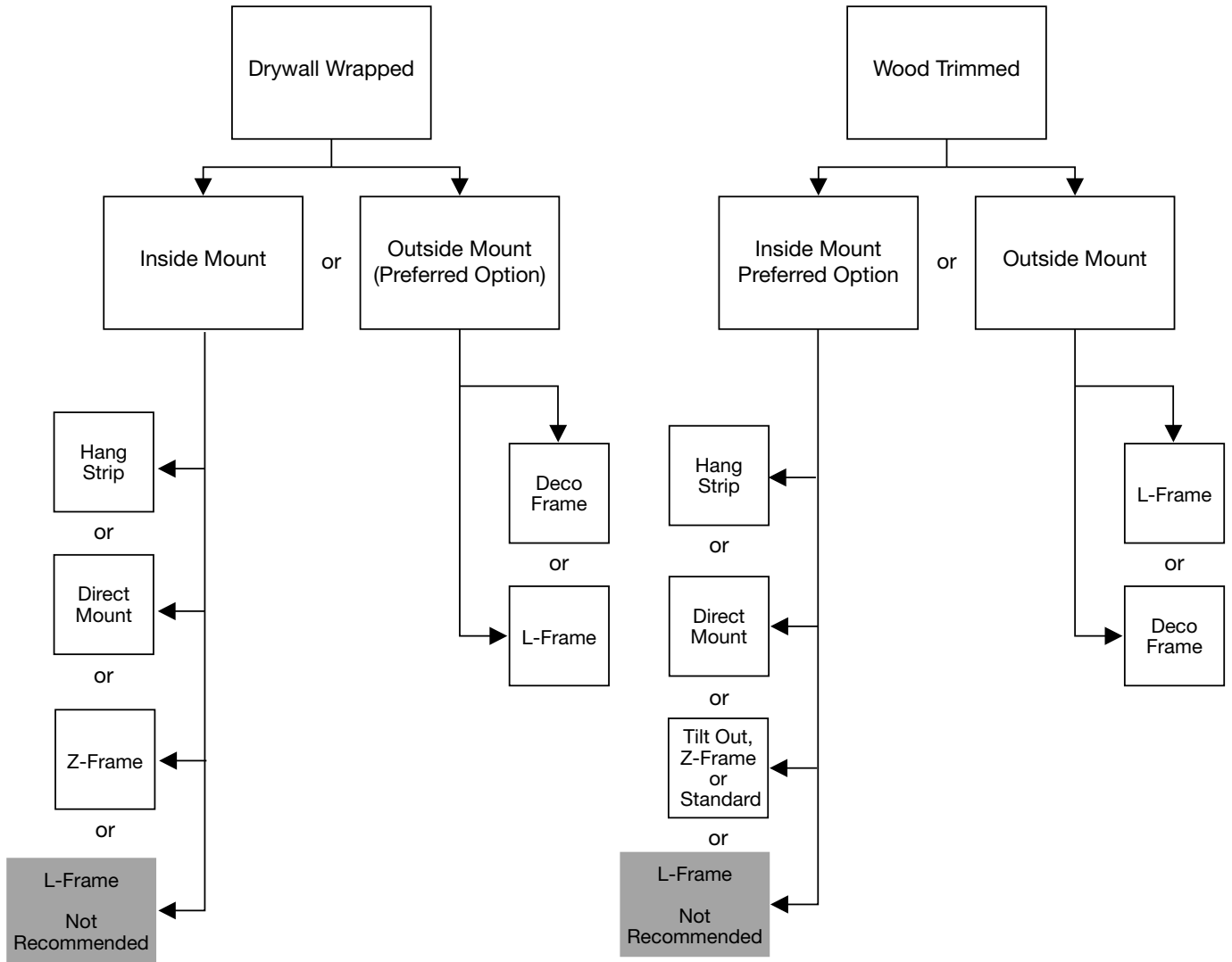

If window has a sill, configuration with a sill bottom is recommended

Options

MEASURING FOR STANDARD SHUTTERS

Confirm that the window is square.

Measure the diagonals. If the difference between the two measurements is greater than $\frac{1}{4}$ ", an outside mount shutter is required.

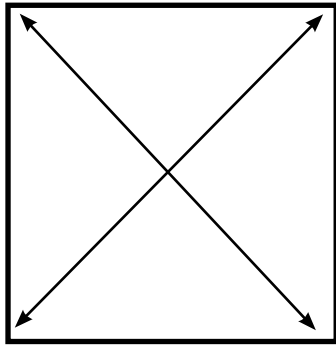

Square

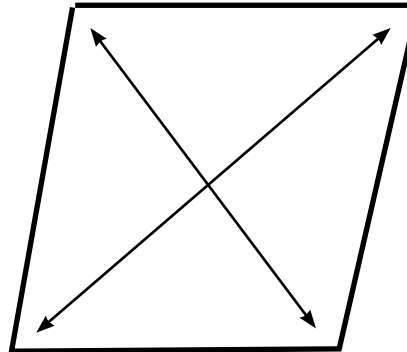

Not Square

Window Opening Measurement

Inside Mount with Hang Strips, Direct Mount, Z-Frame, Tilt-Z

- Measure the width at three points and the height at three points. Use the **smallest** width and height measurements.

NOTE: Factory makes no allowances/deductions for Tilt-Z frame.

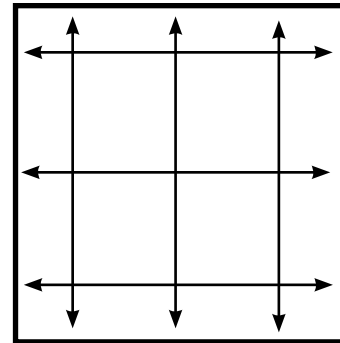

Frame-to-Frame Measurement

Required for L-Frame, Deco Frame and Side Light

- Place a sample of the L-Frame or Deco Frame on the window frame or wall to determine frame-to-frame placement.
- Measure frame-to-frame width at three points and frame-to-frame height at three points. Use the **largest** width and height measurements.

NOTE: At least $1\frac{3}{4}$ " flat surface is needed on each side of the window for an L-Frame.

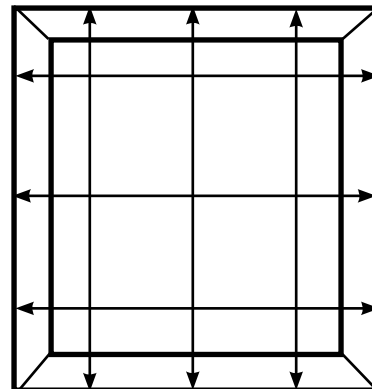

Helpful Hint: If shutters are in the same room and/or side by side, shutters must be ordered at the same height to ensure rail width, divider rail location, louver count and hinge quantity will match.

Options

MEASURING DIVIDER RAIL OR SPLIT TILT LOCATION

To measure frame-to-frame, measure from the bottom of the shutter frame up to the center of the desired rail or split tilt location.

To measure window opening, measure from the sill or bottom of the window opening to the center of the desired rail or split tilt location.

If there are two divider rails, measure from the bottom of measure type up to center of first rail location, then measure from the bottom of measure type up to the center of the second rail location.

Split tilt in only available in one location.

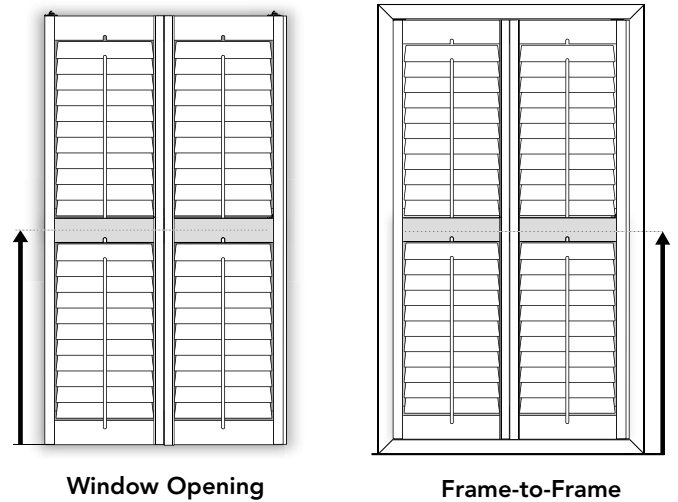

DIVIDER RAIL REQUIREMENTS

1. Divider rails are required over 84" height for added strength.
2. Divider rail can be requested (when not required) for design purposes.
3. A 3" divider rail is used with 2½" and 3½" louvers.
4. A 4" divider rail is used with 4½" louvers.
5. Divider rails for 2½" and 3½" louvers will be as specified on order.
6. Factory may shift rail up or down, (+ or - 2") to achieve uniform louver spacing in 4½" louvers only.
7. Minimum louver set is 2 louvers in each section.
8. Two divider rails available but not required.

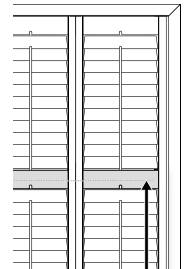

HELPFUL HINT: If shutters are in the same room and/or side by side, shutters must be ordered at the same height to ensure divider rail location will match.

MEASURING T-POST LOCATIONS

Always start from the left point of measure type to the center of the desired T-Post location.

To measure frame-to-frame, measure from the left of the shutter frame to the center of the desired T-Post location.

To measure window opening, measure from the left inside of the window opening to the center of the desired T-Post location.

If there is more than one T-Post, measure from the left of measure type to the center of first T-Post location, then measure from the left of measure type over to the center of the second T-Post location etc. Example A-B, A-C, A-D

ALWAYS measure from the same point the frame was measured. EXAMPLE: If measuring for L-Frame, frame-to-frame measure type, A is the outside edge of the L-Frame.

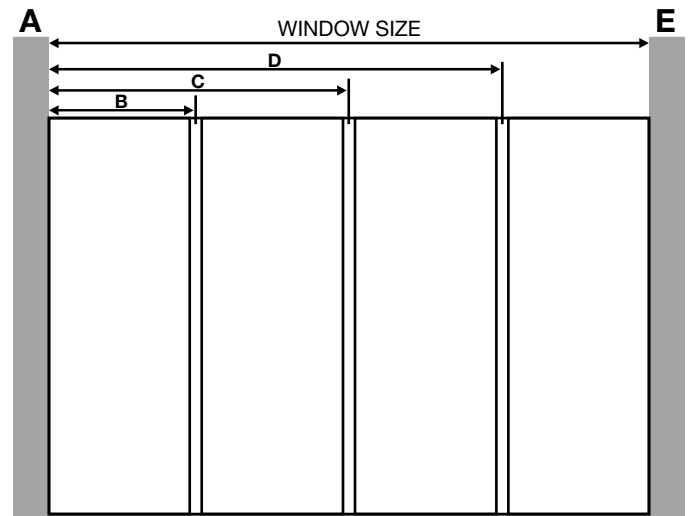

Options

FRAME PRODUCT DETAIL

Direct Mount

- Inside mount only
- Window opening measure only
- Panel is pre-hinged
- Four light blocks included
- Factory automatically makes deductions: Width $\frac{3}{16}$ ", Height $\frac{1}{4}$ "

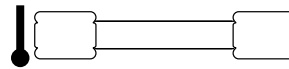
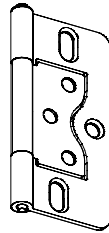

Example: 1-panel L

Frame Hinge

Hang Strip

- Inside mount only
- Window opening measure
- Includes adjustable wrap-around hinge for easy installation
- Panel and hang strip are pre-hinged
- Hang strip is pre-drilled
- Top and bottom light blocks included
- Factory automatically makes deductions: Width $\frac{3}{16}$ ", Height $\frac{1}{4}$ "

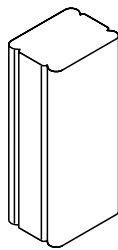

Hang Strip

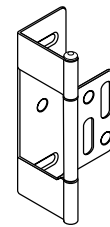

Hang Strip Hinge

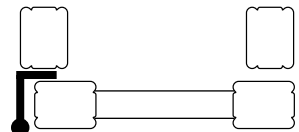

Example: 1-panel L

Z-Frames

- Inside mount only
- Window opening measure only
- Panel and frame are pre-hinged
- Frame is not pre-drilled
- Standard, Signature, Legacy, Bullnose – factory automatically makes deductions: Width $\frac{5}{16}$ ", for Height, see chart

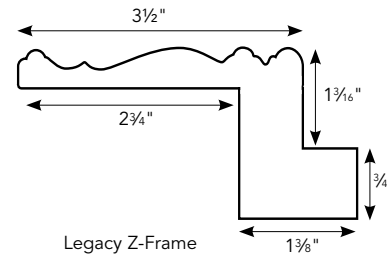

Legacy Z-Frame

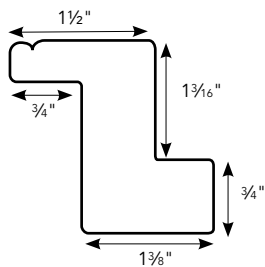

Standard Z-Frame

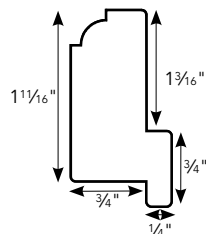

Tilt-Out Z-Frame

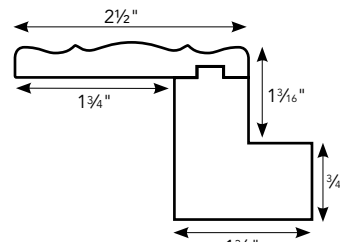

Signature Z-Frame

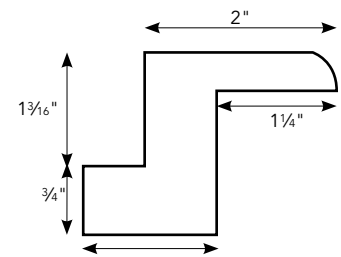

Bullnose Z-Frame

Deco Frames

- Outside mount only
- Frame-to-frame measure only
- Panel and frame are pre-hinged
- Frame is not pre-drilled
- No factory deduction made

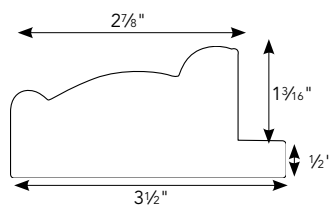

Curved Deco

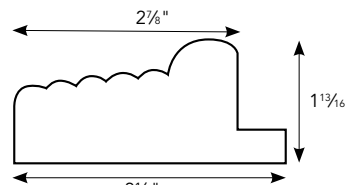

3/2" Deco

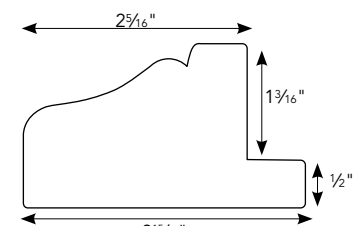

Traditional Deco

Options

FRAME PRODUCT DETAIL

L-Frames

- Recommended outside mount only
- Frame-to-frame measure only
- Panel and frame are pre-hinged
- Frame is not pre-drilled
- No factory deduction made

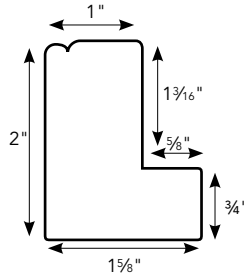

2" Standard L-Frame

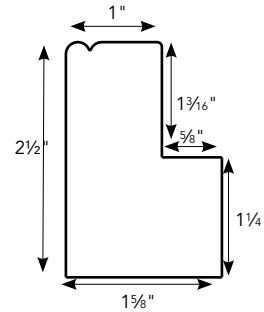

2½" Extended Standard L-Frame

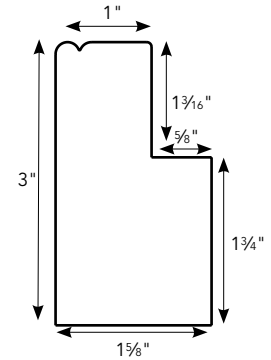

3" Extended Standard L-Frame

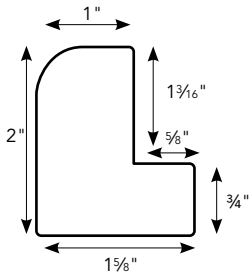

2" Bullnose L-Frame

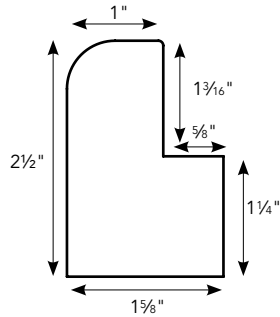

2½" Extended Bullnose L-Frame

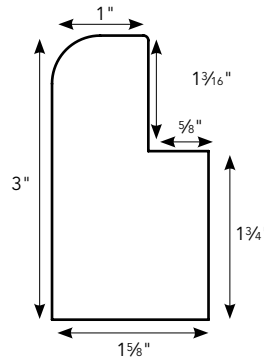

3" Extended Bullnose L-Frame

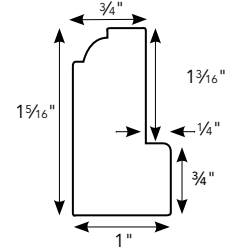

Narrow L-Frame

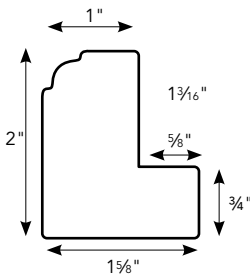

2" Colonial L-Frame

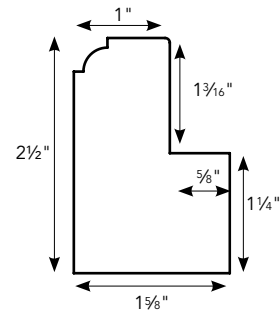

2½" Extended Colonial L-Frame

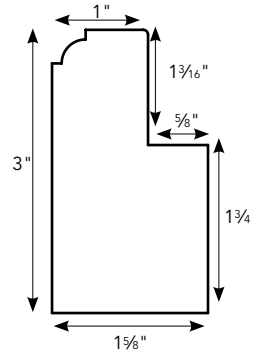

3" Extended Colonial L-Frame

Sill Frames

- Offered with L, Z, and Deco Frames
- Not available with Buildouts
- Not available with extended L-Frame

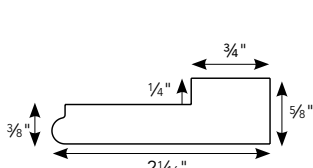

Narrow L-frame Sill Frame

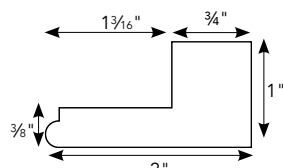

L & Z Sill Frame

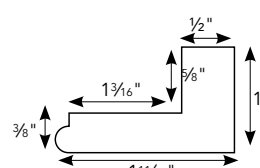

Deco Sill Frame

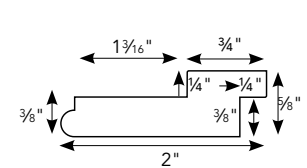

Tilt Z Sill Frame

Options

FRAME PRODUCT DETAIL

Side Light Frame

- Frame-to-frame measure only
- 4-sided configuration only
- Left or right panel configurations only
- 2½" or 3½" louvers only
- Frame shipped assembled
- Buildout available, attached at factory
- See Side Light Frame section for more information

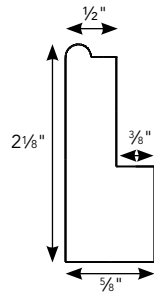

Side Light Frame

Light Block

- Included with hang strip, direct mount, 2-sided, and 3-sided frame types

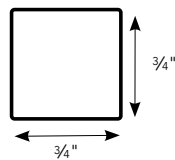

Light Block

T-Post

- Vertical post that divides the panel into two sections
- T-Post pre-drilled by factory

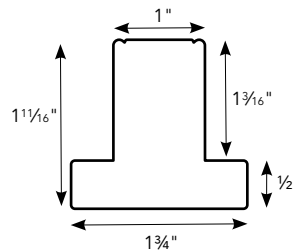

Deco T-Post

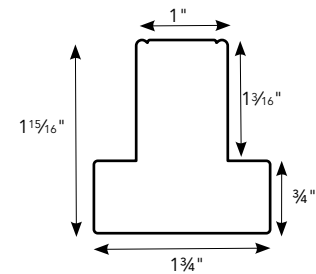

Standard T-Post

Buildout

- Used with L-Frames, Extended L, Deco Frames, and Sidelight Frame
- Available only in ½"
- Maximum 2" (4 pieces) per shutter
- Not available with sill configurations

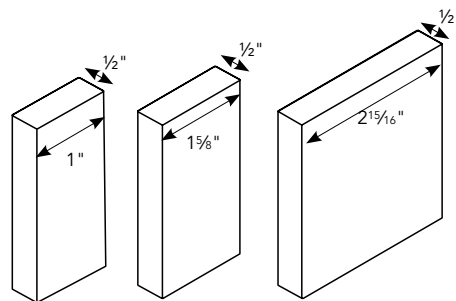

Narrow L Frame Buildout

L-Buildout

Deco-Buildouts

Corner Posts and Bay Posts

- A vertical post used for installing shutters in bay and corner windows
- See Corner and Bay Post section for more information

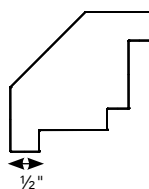

Deco
½" Corner Post

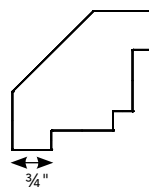

Standard
¾" Corner Post

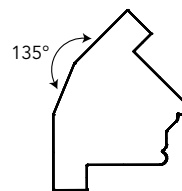

Deco
½" Bay Post

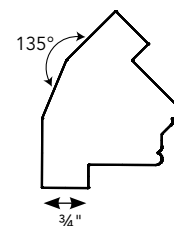

Standard
¾" Bay Post

Specifications

DEDUCTIONS FOR FRAME ALLOWANCES

Direct Mount

- Automatically taken at factory
- Width deduction; $\frac{3}{16}$ "
- Height deduction; $\frac{1}{4}$ "

Hang Strip

- Automatically taken at factory
- Width deduction; $\frac{3}{16}$ "
- Height deduction " $\frac{1}{4}$ "

Z-Frame (Standard, Signature, Legacy, Bullnose)

- Automatically taken at factory

Z-Frame Configuration	Frame Width Deduction	Frame Height Deduction
2-Sided	- $\frac{5}{16}$ "	No deduction*
3-Sided or 3-Sided Inverted	- $\frac{5}{16}$ "	- $\frac{5}{32}$ "*
3-Sided Sill Top or Bottom	- $\frac{5}{16}$ "	- $\frac{1}{16}$ "*
4-Sided	- $\frac{5}{16}$ "	- $\frac{5}{16}$ "
4-Sided Sill Top or Bottom	- $\frac{5}{16}$ "	- $\frac{5}{32}$ "
4-Sided Sill Top and Bottom	- $\frac{5}{16}$ "	- $\frac{1}{16}$ "
The information above does not apply to Tilt Z-frame. *Using this deduction, panel clearance on open ends of frame will automatically be $\frac{1}{8}$ ".		

NOTE: Factory makes no deductions on Tilt-Z Frames.

L-Frames

- No deductions taken at factory
- If using for inside mount or in a tight spot, installer must make own deduction for proper fit

Deco Frame

- No deduction taken at factory
- If using in a tight spot, installer must make own deduction for proper fit

Specifications

FRAME CONFIGURATIONS

2-Sided

Hang strip with inside mount is available only in 2-sided frame (vertical). We will provide the light block at no charge for hang strip with inside mount.

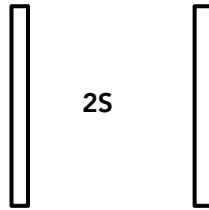

Direct Mount

No frame. Hinge-to-jamb. Furnished with light block for all 4 sides.

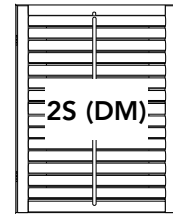

3-Sided

Light block included at no charge.

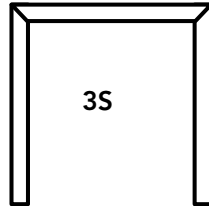

4-Sided with Sill Bottom

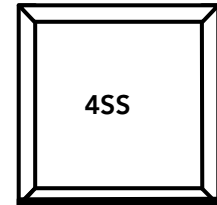

3-Sided Inverted

Light block included at no charge.

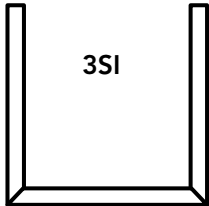

4-Sided with Sill Top

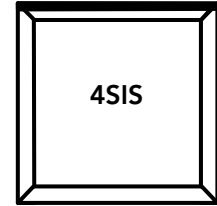

3-Sided with Sill Top

Light block included at no charge.

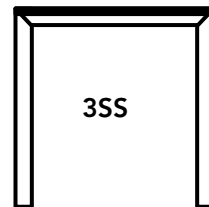

4-Sided

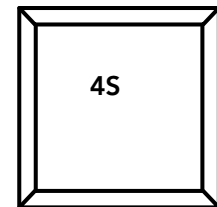

3-Sided Inverted with Sill Bottom

Light block included at no charge.

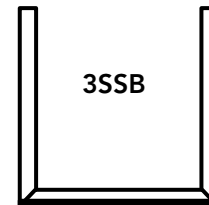

4-Sided with Sill Top and Bottom

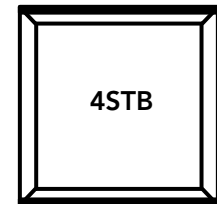

NOTE: Direct mount includes four light blocks at no charge.

Specifications

INSTALLATION HARDWARE

Included with order

- Hinge pins
- Installation screws (hinge, mounting, etc.)
- Touch up paint dabber – paints only
Due to top coat process, touch-up bottles are NOT provided with stains but can be requested
- Hoffman keys

Available upon request – contact Customer Service

- Hinge shims
- Louver pins
- Screw caps (cover exposed screw heads)
- Screws

Specialty Styles

CAFÉ SHUTTERS

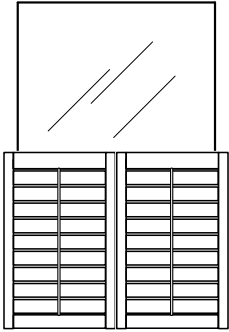

Shown as 2-Sided

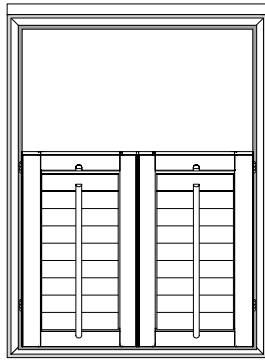

Shown as 4-Sided

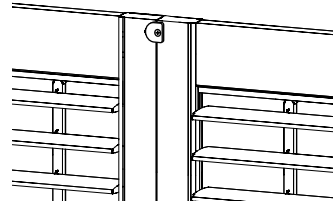

Rear view of Café Panel

Optional: Café Aligning Catch

- Tops of wood panels are finished
- Café shutter panels cover the lower portion of the window
- Pricing is width x café panel height
- Optional Café Aligning Catch
- Frame can be ordered to stop at panel height or can be ordered to fully frame the window

Specialty Styles

SUNBURST ARCH WITHOUT FRAME

Specialty Shape Without Frame: Panel Only

- Sunburst pattern – no horizontal louvers
- Beveled louvers for maximum light control
- Louver sizes will vary based on height and width of arch
- The arch has no tilt bar; the louvers open individually and are spring loaded at the bottom pin
- All wood and composite colors available. Wood arches can be matched to composite colors
- Buildouts not available
- Panel is 1" thick and may not match projection of other outside mount standard shutters
- Order arch as frame-to-frame

• Allow sufficient wall space to mount. Panel-only arches that are:

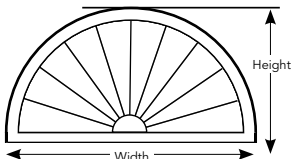
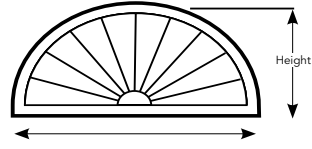
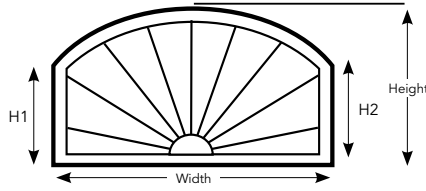
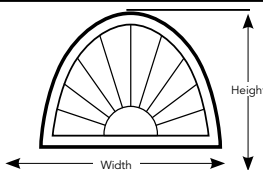

WOOD Frameless Arch Base Width	Top Rail Size	Bottom Rail Size
20" to less than 24"	2"	1"
20" to less than 45"	3"	2"
45" to less than 80"	3"	3"
80" to 108"	4"	4"

NOTE: If mounting arch inside, take own deduction. Template recommended.





Specialty Shape Without Frame: Minimum and Maximum Sizes				
Frameless - Panel Only	Width		Height	
	Minimum	Maximum	Minimum	Maximum
 <p>Half-round Sunburst Arch Height = 50% of width No templates required</p>	20"	108"	10"	54"
 <p>Eyebrow Sunburst Height Minimum = no less than 33% of width Height Maximum = no greater than 66% of width Template required if height exceeds 54% of width</p>	20"	108"	7"	54"
 <p>Elongated Sunburst Height Minimum = no less than 33% of width Height Maximum = no greater than 66% of width Template required if ordered height minus ordered leg height exceeds 54% of width</p>	20"	108"	7"	71¼"
 <p>Elliptical Sunburst All elliptical arches need a template</p>	20"	108"	7"	71¼"

Specialty Styles

SUNBURST ARCH WITH FRAME

			
Frame Options	Z-Frames*	L-Frames	Deco Frame
Mount	Inside Mount Only	Outside Mount Only	Outside Mount Only
Order Size	Window Opening	Frame-to-Frame	Frame-to-Frame
Projection	3/8"	2"	1 ¹ / ₁₆ " or 1 ³ / ₁₆ "

NOTE: All frame types are available with sill bottom
 Buildouts are available on L-Frame and Deco Frame arches.
 *Framed arches not available with Tilt-Z frame, Bullnose Z or Extended L frames

Framed Arch Z-Frames 	Half Round	Width		Height	
	Eye brow	Min.	Max.	Min.	Max.
	Elongated	21 ¹³ / ₁₆ "	109 ¹³ / ₁₆ "	11 ¹³ / ₁₆ "	55 ¹³ / ₁₆ "
	Elliptical	21 ¹³ / ₁₆ "	109 ¹³ / ₁₆ "	8 ¹³ / ₁₆ "	73 ¹ / ₁₆ "
		21 ¹³ / ₁₆ "	109 ¹³ / ₁₆ "	8 ¹³ / ₁₆ "	73 ¹ / ₁₆ "
Framed Arch L-Frames 	Half Round	Width		Height	
	Eye brow	Min.	Max.	Min.	Max.
	Elongated	22 ¹ / ₈ "	110 ¹ / ₈ "	12 ¹ / ₈ "	56 ¹ / ₈ "
	Elliptical	22 ¹ / ₈ "	110 ¹ / ₈ "	9 ¹ / ₈ "	56 ¹ / ₈ "
		22 ¹ / ₈ "	110 ¹ / ₈ "	9 ¹ / ₈ "	73 ³ / ₈ "
Framed Arch 3" Deco Frames 	Half Round	Width		Height	
	Eye brow	Min.	Max.	Min.	Max.
	Elongated	24 ³ / ₄ "	112 ³ / ₄ "	14 ³ / ₄ "	58 ³ / ₄ "
	Elliptical	24 ³ / ₄ "	112 ³ / ₄ "	11 ³ / ₄ "	58 ³ / ₄ "
		24 ³ / ₄ "	112 ³ / ₄ "	11 ³ / ₄ "	76"
Framed Arch 3¹/₂" Deco Frames 	Half Round	Width		Height	
	Eye brow	Min.	Max.	Min.	Max.
	Elongated	25 ⁷ / ₈ "	113 ⁷ / ₈ "	15 ⁷ / ₈ "	71 ¹ / ₈ "
	Elliptical	25 ⁷ / ₈ "	113 ⁷ / ₈ "	12 ⁷ / ₈ "	59 ⁷ / ₈ "
		25 ⁷ / ₈ "	113 ⁷ / ₈ "	12 ⁷ / ₈ "	77 ¹ / ₈ "

Specialty Styles

FRAMED ARCH INSTALLATION OPTION

Arches arrive with the louvers not installed and packed separately. Louvers are numbered on bottom edge from right to left on the bottom as you look at the interior (room) side.

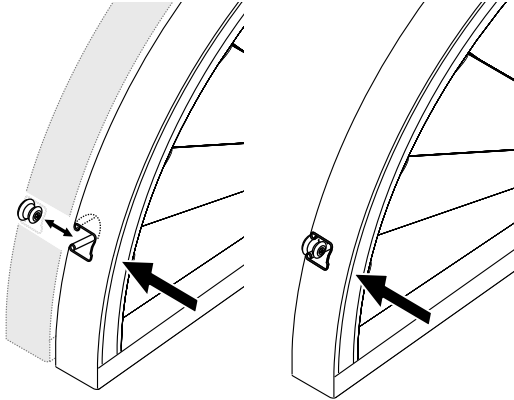

Framed Arch – Installing Panel to Frame

Button catch (imbedded) is standard. Panels are attached to frame via button catch. The frame itself installs as a standard L, Z or Deco frame.

FRAMELESS ARCH INSTALLATION OPTION

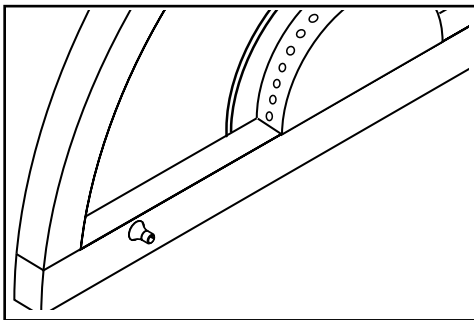

Bulldog Catch

Bulldog catch works best with window openings that have a square edge. Allows arch panel to be removed for cleaning. Available in White.

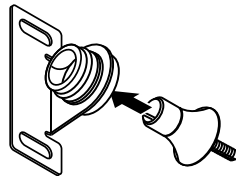

Suggested quantity usage: Less than 36" – 3
 36" to 72" – 5
 72" to 108" – 7

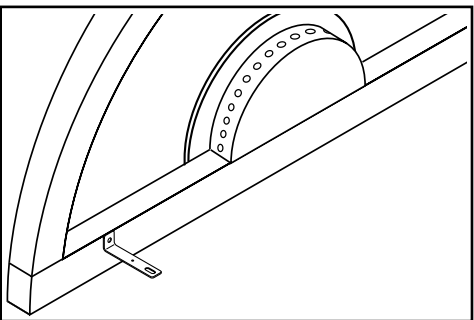

L-Bracket

L-bracket works best with windows that have a bull-nosed edge. Long-throw on the L-bracket allows you to reach past the curved window edge to a flat surface. L-bracket is zinc colored only.

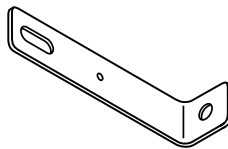

Suggested quantity usage: Less than 36" – 5
 36" to 72" – 7
 72" to 108" – 9

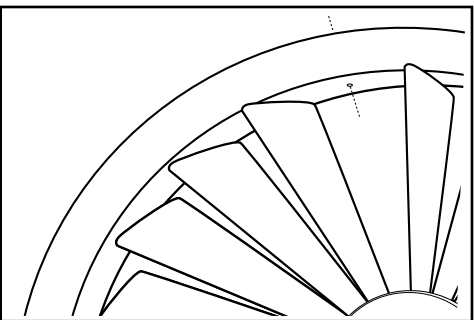

Trim Head Screw

If using trim head screws to mount, pilot a hole diagonally from underside of curved frame and exit through rear of frame. Place screw hole near louver pin to help hide hole from view.

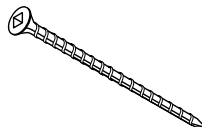

Specialty Styles

ARCHED PANEL SHUTTER AND ANGLED TOP PANEL

- 2½", 3½" & 4½" louvers available
- All wood colors available. Wood arched or angled panel can be matched to composite colors
- Astragal, Hide-a-Tilt™ and Split Tilt available
- **NOTE:** Hide-a-Tilt only tilts up
- All frames except Tilt Z available
- All panel configurations in standard shutters available
- Available frame configurations: 3-Sided (3S), 4-Sided (4S) and 4-Sided with Sill Bottom (4SS)

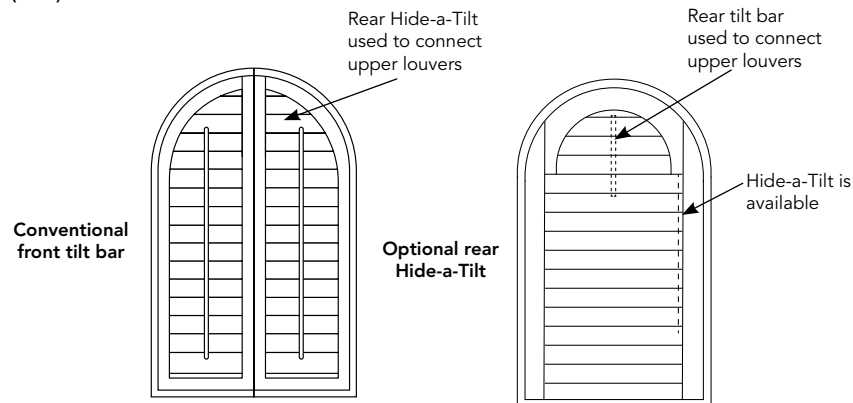

Louver Tilt is restricted up to 90 degrees

Louver tilt is restricted up to 90 degrees due to the curvature (or slope) at the top of the panel. A divider rail can be used to separate the upper arch portion from the lower rectangular portion. This will allow for full louver rotation of the louvers below the divider rail.

MEASURING LEG HEIGHT AND DIVIDER RAIL HEIGHT FOR WINDOW OPENING

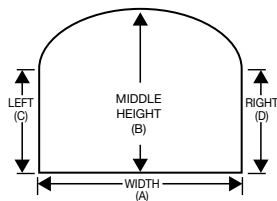

Frames requiring WO measurement:
Z-frame, Hang Strip, and Direct Mount.

Measuring leg height:

Measure from bottom of window up to arch "break point."

Measuring divider rail height:

Measure from bottom of window up to center of divider rail.

MEASURING LEG HEIGHT AND DIVIDER RAIL HEIGHT FOR FRAME-TO-FRAME MEASUREMENT

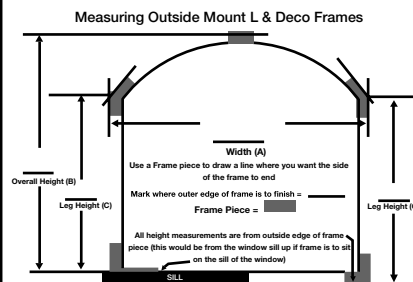

Frames requiring F2F measurement:

L-Frames and Deco frames

Measure leg height:

Measure from bottom edge of frame up to arch "break point" inside the window (C).

Measuring divider rail height:

Measure from bottom of frame up to center of each divider rail.

NOTE: Divider rail requirements are the same as standard shutters.

Specialty Styles

ARCHED PANEL MINIMUM AND MAXIMUM WIDTH ORDER SIZES BY PANEL CONFIGURATION: 2 1/2", 3 1/2" & 4 1/2" LOUVERS

PANEL CONFIGURATION	Examples of shutter configurations with combinations of panels and T-Posts	DIRECT MOUNT, HANG STRIP, TILT OUT Z-FRAMES		Z-FRAMES		L-FRAMES		NARROW L-FRAME		3" TRADITIONAL DECO FRAME		3 1/2" CURVED DECO FRAMES	
		Order W-O Size		Order W-O Size		Order F-F Size		Order F-F Size		F-F Size		F-F Size	
		Minimum Width	Maximum Width	Minimum Width	Maximum Width	Minimum Width	Maximum Width	Minimum Width	Maximum Width	Minimum Width	Maximum Width	Minimum Width	Maximum Width
1 Panel		9 1/16"	36 3/16"	11"	38"	11 3/16"	38 3/16"	10 1/16"	37 1/16"	13 13/16"	40 13/16"	14 15/16"	41 15/16"
2 Panel		18 1/16"	72 1/16"	19 7/8"	73 7/8"	20 1/16"	74 1/16"	19 9/16"	73 9/16"	22 1/16"	76 1/16"	23 13/16"	77 13/16"
2 Panel, 1 T-Post		19 3/8"	73 3/8"	21 3/16"	75 3/16"	21 3/8"	75 3/8"	20 7/8"	74 7/8"	24"	78"	25 5/8"	79 5/8"
1 Bi-Fold		18 1/16"	52 1/16"	19 7/8"	53 7/8"	20 1/16"	54 1/16"	19 9/16"	53 9/16"	22 1/16"	56 1/16"	23 13/16"	57 13/16"
1 Panel, 1 Bi-Fold		27 1/4"	88 1/4"	29 1/16"	90 1/16"	29 1/4"	90 1/4"	28 3/4"	89 3/4"	31 7/8"	92 7/8"	33"	94"
1 Panel, 1 Bi-Fold, 1 T-Post		28 1/4"	89 1/4"	30 1/16"	91 1/16"	30 1/4"	91 1/4"	29 3/4"	90 3/4"	32 7/8"	93 7/8"	34"	95"
3 Panel, 1 T-Post		28 1/4"	109 1/4"	30 1/16"	111 1/16"	30 1/4"	111 1/4"	29 3/4"	110 3/4"	32 7/8"	113 7/8"	34"	115"
3 Panel, 2 T-Post		29 1/16"	110 1/16"	31 3/8"	112 3/8"	31 1/16"	112 1/16"	31 1/16"	112 1/16"	34 3/16"	115 3/16"	35 5/16"	116 5/16"
2 Bi-Fold		36 3/16"	104 3/16"	38 7/8"	106 7/8"	38 3/16"	106 3/16"	37 13/16"	105 13/16"	40 15/16"	108 15/16"	42 1/16"	110 1/16"
2 Bi-Fold, 1 T-Post		37 1/8"	105 1/8"	38 15/16"	106 15/16"	39 1/8"	147 7/8"	38 7/8"	106 7/8"	41 3/4"	109 3/4"	47 7/8"	110 7/8"
4 Panel, 1 T-Post		37 1/8"	145 1/8"	38 15/16"	146 15/16"	39 1/8"	147 7/8"	38 7/8"	146 7/8"	41 3/4"	149 3/4"	42 7/8"	150 7/8"
4 Panel, 2 T-Post		38 7/16"	146 7/16"	40 1/4"	148 1/4"	40 1/16"	148 1/16"	39 15/16"	147 15/16"	43 1/16"	151 1/16"	44 3/16"	152 3/16"
4 Panel, 3 T-Post		39 3/4"	147 3/4"	41 1/16"	149 1/16"	41 1/4"	149 1/4"	41 1/4"	149 1/4"	44 3/8"	152 3/8"	45 1/2"	153 1/2"
5 Panel, Bi-Fold, 2 T-Post		47 5/8"	162 5/8"	51 1/4"	166 1/4"	51 5/8"	166 5/8"	51 1/8"	166 1/8"	56 7/8"	171 7/8"	51 1/8"	174 1/8"
5 Panel, Bi-Fold, 2 T-Post		47 5/8"	162 5/8"	51 1/4"	166 1/4"	51 5/8"	166 5/8"	51 1/8"	166 1/8"	56 7/8"	171 7/8"	51 1/8"	174 1/8"
5 Panel, 2 T-Post		47 5/16"	182 5/16"	50 15/16"	185 15/16"	51 3/16"	189 3/16"	50 11/16"	188 11/16"	54 13/16"	194 13/16"	59 1/16"	195 1/16"
5 Panel, 4 T-Post		49 15/16"	184 15/16"	53 3/16"	188 3/16"	53 15/16"	188 15/16"	53 1/16"	188 1/16"	57 5/16"	193 5/16"	60 1/16"	195 1/16"
5 Panel, 4 T-Post		49 15/16"	184 15/16"	53 3/16"	188 3/16"	53 15/16"	188 15/16"	53 1/16"	188 1/16"	57 5/16"	193 5/16"	60 1/16"	195 1/16"
6 Panel, 2 Bi-Fold, 2 T-Post		56 3/16"	178 1/16"	58 1/2"	180 1/2"	58 1/16"	180 1/16"	59	181	61 1/16"	183 5/16"	62 1/16"	184 7/16"
6 Panel, 2 T-Post		56 3/16"	218 3/16"	58"	220"	58 3/16"	220 3/16"	57 11/16"	219 11/16"	60 13/16"	222 13/16"	61 5/16"	223 5/16"
6 Panel, 2 Bi-Fold, 3 T-Post		57 1/2"	179 1/2"	59 5/16"	181 5/16"	59 1/2"	181 1/2"	60	181	62 1/8"	184 1/8"	63 1/4"	185 1/4"
6 Panel, 5 T-Post		60 1/8"	222 1/8"	61 15/16"	223 15/16"	62 1/8"	224 1/8"	61 5/8"	233 5/8"	64 3/4"	226 3/4"	65 7/8"	227 7/8"
8 Panel, 2 Bi-Fold, 2 T-Post		73 15/16"	249 15/16"	75 3/4"	251 3/4"	75 15/16"	251 15/16"	75 1/16"	251 1/16"	78 1/16"	254 1/16"	79 1/16"	255 1/16"
8 Panel, 4 Bi-Fold, 2 T-Post		73 15/16"	209 15/16"	75 3/4"	211 3/4"	75 15/16"	211 15/16"	75 1/16"	211 1/16"	78 1/16"	214 1/16"	79 1/16"	215 1/16"
8 Panel, 3 T-Post		75 1/4"	291 1/4"	77 7/16"	293 7/16"	77 1/4"	293 1/4"	76 3/4"	292 3/4"	79 7/8"	295 7/8"	81"	297"

Windows larger than 105" may require splicing for the frame.

Specialty Styles

ARCHED PANEL

Ordered Height Limitations for Arched and Angle Top Shutters

	Frame Configuration	Frame type	Minimum		Maximum
			2.5/3.5 Louvers	4.5 Louver	2.5/3.5/4.5 Louver
Window Opening	2-sided	Hang strip/direct mount	15¼	20¼	120¼
	3-sided	Z-Frames	16⅛	21⅛	121⅛
	4-sided with sill bottom	Z-Frames	16⅞	21⅞	121⅞
	4-sided	Z-Frames	17⅙	22⅙	122⅙
Frame-to-Frame	3-sided	L-Frame	16¼	21¼	121¼
	4-sided with sill bottom	L-Frame	16¾	21¾	121¾
	4-sided	L-Frame	17¼	22¼	122¼
	3-sided	Deco curve	18⅞	23⅞	123⅞
	4-sided with sill bottom	Deco curve	18½	23½	123½
	4-sided	Deco curve	21	26	126
	3-sided	Traditional deco	17⅙	22⅙	122⅙
	4-sided with sill bottom	Traditional deco	17 ¹⁵ ⁄ ₁₆	22 ¹⁵ ⁄ ₁₆	122 ¹⁵ ⁄ ₁₆
4-sided	Traditional deco	19⅞	24⅞	124⅞	

Tilt Z, Bullnose Z, Extended L, Narrow L not available.

FRENCH DOOR OPTIONS

- 2½", 3½" and 4½" louvers
- Hide-a-Tilt™, Split Tilt and Double Mouse Hole available
- All wood colors available. Wood French Doors can be matched to composite colors
- Single panels hinged on the same side as the door
- L-Frames include Standard L, Bullnose L and Colonial L
- Narrow L-Frame not available
- Order frame-to-frame
- Outside mount only
- Divider rails are not available
- Buildouts can be requested at time of order. Extended L-Frames provided as necessary
- Button catches plus magnets are standard to provide for a secure closure

NOTE: All French Door shutters for cut-out and no cut-out should be ordered at the same time.

Projection Based on Louver Size	Frame
2½"	2" L-Frame
3½"	2½" L-Frame
4½"	3" L-Frame

Manufacturing will automatically use a larger L-Frame projection to your order according to the louver size. An additional ½" or 1" can also be requested if needed for louver clearance on larger trims. Factory will also make all adjustments to back plate elevation based on trim projection and extra buildout requested.

Specialty Styles

FRENCH DOOR OPTIONS

CUT-OUT OPTIONS

L-Frame
No Cut-out

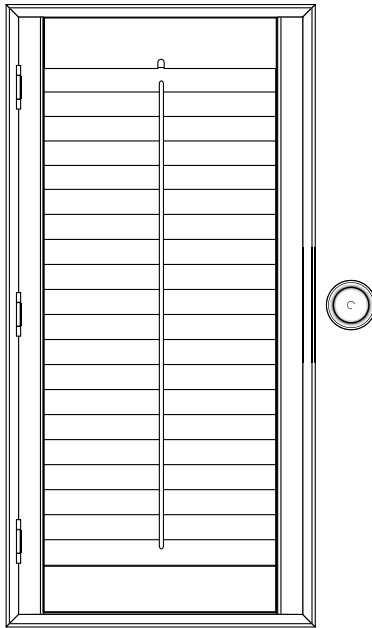

This should only be ordered when installed next to a French door with cut-out, otherwise order it as a standard shutter.

Rectangular Cut-out
(Surcharge applies)

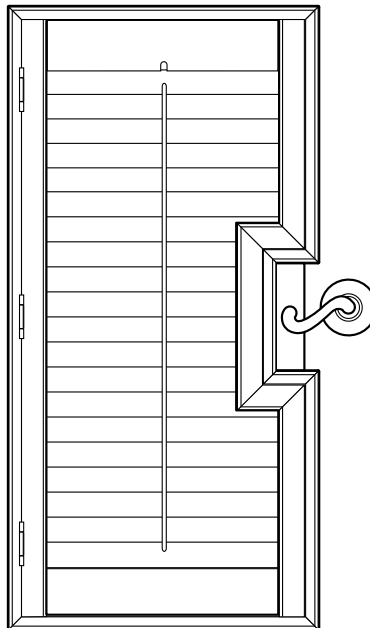

Curved Cut-out
(Surcharge applies)

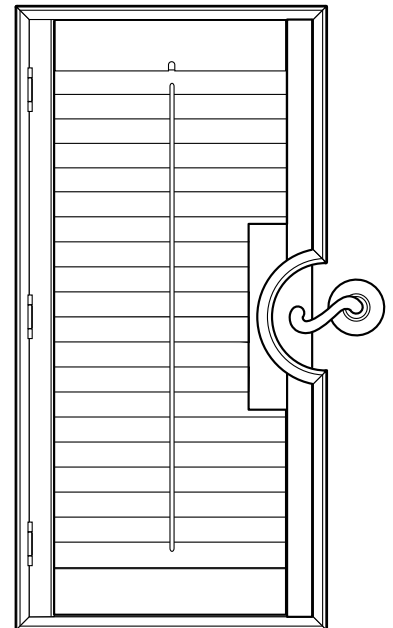

Order Rectangular Cut-out when:

1. Choose if the base of the door hardware is rectangular.
2. Must specify width and height of the cut-out. There are NO set standard sizes to conform to. There are NO templates to use.
3. Be sure to make proper allowances for the door handle to pivot easily when determining your cut-out size.

Order a Curved Cut-out when:

1. Choose a cut-out if the base of the door handle (or knob) is round.
2. Five (5) standard cut-out sizes are available: Three (3) half-circles and two (2) half-ovals.
3. Other custom sizes of curved cut-outs are NOT available.
4. Be sure to make proper allowances for the door handle to pivot easily when determining your cut-out size.

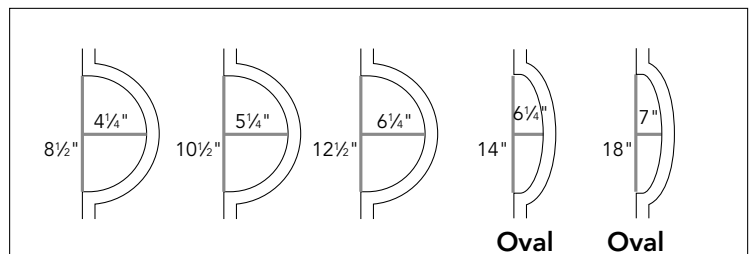

This image is taken from the backside of the French door order form.

Specialty Styles

FRENCH DOOR OPTIONS

MINIMUM/MAXIMUM FRENCH DOOR SIZES

	Minimum	Maximum
Width	16 $\frac{3}{4}$ "	38 $\frac{1}{4}$ "
Height	37 $\frac{3}{4}$ "	90 $\frac{1}{4}$ "

Placement of L-Frame

L-Frame always sits outside of the trim, never on the trim. If no raised trim, place the L-Frame far enough beyond the glass to rest totally flat on the door and to avoid risk of breaking the glass when driving the mounting screws in place. Use caution when placing screws, as the glass often extends under the trim and could easily crack.

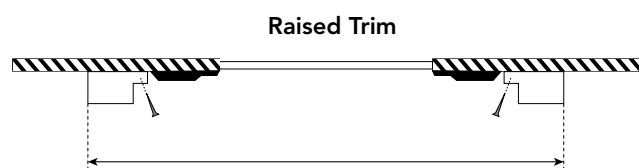

Always use **frame-to-frame measure format** for French doors

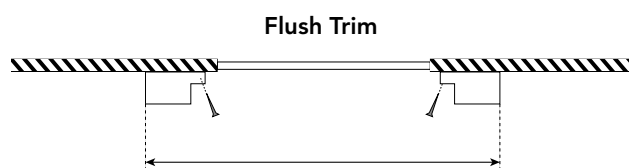

Always use **frame-to-frame measure format** for French doors

A "recessed back plate" is required when there is insufficient space between the base of the door hardware and the glass trim to place L-Frame flat on the door surface.

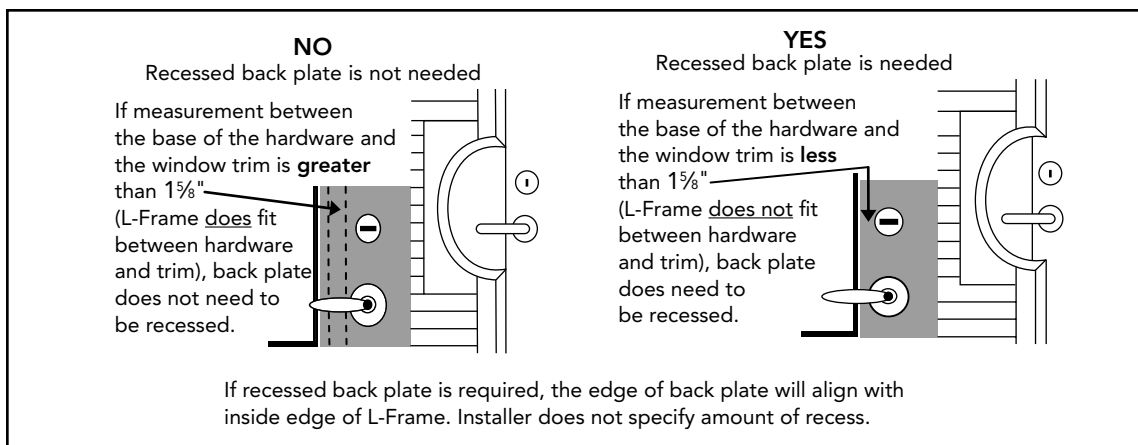

Caution:

1. When measuring (F-F) width and height, be sure that L-Frame can rest flat on the door surface and not be obstructed by the glass trim.
2. If "yes" is selected, the edge of the recessed back plate will be built to align with the inside edge of the L-Frame (as shown by the dotted line in the upper drawing).

Specialty Styles

BYPASS SHUTTERS

- Ideal solution for large windows and patio doors
- System consists of a double-top track and floor guides
- All wood colors options available
- Available in 2½" and 3½" louver sizes
- Available with Hide-a-Tilt™ and Split Tilt
- Available with Double Mouse Hole
- See the minimum and maximum order sizes charts (Factory to determine panel size based on width ordered and configuration.)
- Divider rail required over 84" ordered height
- Tracks wider than 144" will be spliced
- Header and valance could be spliced over 96"
- Configuration Options:
 - Outside mount with Box-out
 - Outside mount without Box-out
 - Outside mount with full Stackback (with or without Box-out) or custom header
 - Inside mount, minimum window depth 5⅜"
- Outside mount with 3-sided Box-out is recommended

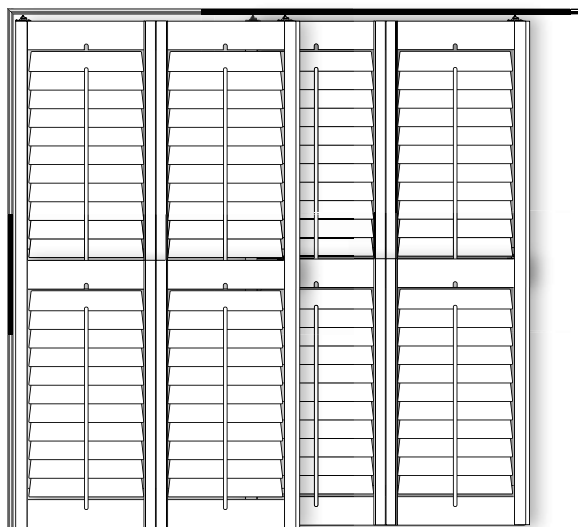
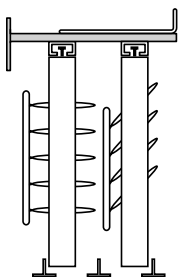

NOTE: Louvers must be closed in order for panels to pass each other.

Specialty Styles

BYPASS SHUTTERS

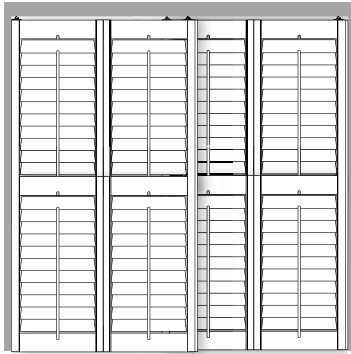

Outside Mount Notes

Width Measure (with Box-out): Order window opening size. If no window trim, measure window opening size. If window trim: measure outside edge of trim to outside edge of trim. Regardless of order size, **factory will add 3¼" to your overall ordered width.** Note: When measuring, add more for bullnose so that frames mount completely on flat surface.

Width Measure (without Box-out): If no window trim: measure window opening. If window trim: measure outside edge of trim to outside edge of trim. **Factory will add 1¼" to your overall order width.** Note: When measuring, add more to extend beyond window edge for privacy purposes.

Height Measure (with or without Box-out): If no window trim: measure from floor surface to top of the window opening. If window trim: measure to top of window trim. **Factory will add 2⅝" to your overall order height.**

Other Measuring Considerations: If there are window moldings, factory can only accommodate up to ½" thick molding when using 3½" louvers and Hide-a-Tilt™.

Track and Header Board: Unit includes two tracks installed to header. Header is 5½" deep and ¾" thick.

Valance and Returns: Two top treatment styles are available; standard 5" double-bead Valance and the optional 4½" Classic Cornice. Valance returns are included and wrap around the outside of the box out (frame). Returns are mitered and are 5⅞" (inside measure).

Box-out (side frames): Optional Box-out (side frames) are available for outside mount bypass shutters.

Stackback: Optional stack-back is available for outside mount bypass shutters. Custom stack-back widths are available.



Inside Mount Notes

Width Measure: Order W-O (window opening) and provide net window width. **Factory will make a ½" deduction off the track for proper fit.**

Height Measure: Order W-O (window opening) and provide net window height. **Factory will make approximately ½" deduction.** Carriers are adjustable.

Other Measuring Considerations: Minimum window depth requirement 5⅞".

Track and Header Board: Header board is furnished. Tracks mount to head board. Header mounts to window head.

Valance and Returns: Two top treatment styles are available; standard 5" double-bead Valance and the optional 4½" Classic Cornice. No returns are available. Valance end is not mitered.

Box-out (side frames): Box-out (side frames) are not available.

Stackback: Stackback is not available for inside mount bypass shutters.

VALANCE OPTIONS

4½" Decorative Valance



5" Standard Valance



Specialty Styles

BYPASS TRACK SYSTEM CONFIGURATION OPTIONS—ONLY CONFIGURATIONS AVAILABLE

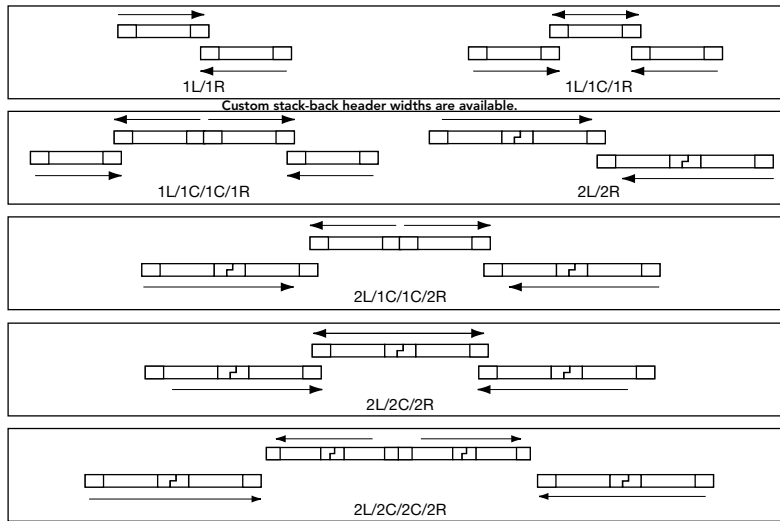

BYPASS SHUTTER – MINIMUM/MAXIMUM WIDTH ORDER SIZES BY PANEL CONFIGURATION

Panel Configuration	Example of shutter unit configurations using various panel combinations	Outside Mount*		Inside Mount	
		Order W-O Size		Order W-O Size	
		Minimum Width	Maximum Width	Minimum Width	Maximum Width
1L / 1R		18"	70"	20"	71"
1L / 1C / 1R		27½"	104"	28½"	106½"
1L / 1C / 1C / 1R		37"	141"	38"	142"
2L / 2R		37¾"	141¾"	38¾"	142¾"
2L / 1C / 1C / 2R		56"	212"	58⅞"	213"
2L / 2C / 2R		57⅞"	213⅞"	58⅞"	213"
2L / 2C / 2C / 2R		76½"	284½"	77½"	285½"

*Same minimum/maximum sizes apply if ordered with Stackback options and with or without Box-out.

Wood Bypass Height Minimum and Maximum		
Options	Minimum	Maximum
Outside mount	15⅜"	120⅜"
Inside mount	17¼"	122¼"

SETTING BRACKET HEIGHT

(for outside mount without side frames)

For Wall Mount Bypass Shutter System
Top of Angle Bracket to Floor:

Top of bracket will be 3⅞" above ordered height. This includes ½" clearance off the floor.

Note: With optional Box-out, side frames determine the mounting height. Bottom edge of side frame is meant to touch the floor surface.

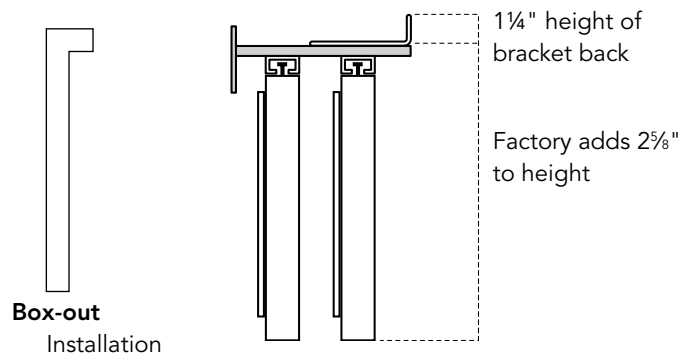

Specialty Styles

BYPASS TRACK SYSTEM

Stackback Option

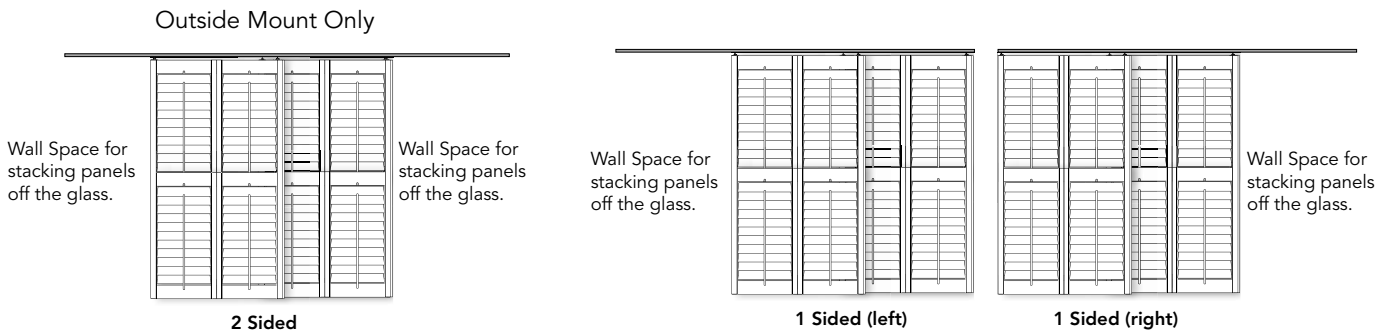

The Stackback option allows for the shutter panels to clear the window opening, creating an unobstructed view. **Panels made to cover window. Header/track made larger so panels stack off glass.**

Measure only the window opening area for outside mount with Stack-back. Factory will calculate the correct Stack-back needed for full Stack-back. Custom header also available.

System consists of a double-top track and floor guides

Calculating Approximate Stackback: Factory will add additional width to ordered size for Stackback. Amounts vary, depending on the number of panels. See chart below for total (approximate) amount that will be added to the window opening size. This determines the approximate overall unit width.

% of Window Opening Size Added for Various Numbers of Panels				
2	3	4	6	8
50%	66%	50%	66%	50%

Custom Header

If wall space is not available for complete stackback, custom header size may be ordered. Give window opening size and custom header size.

Configuration Options:

- Outside mount with Box-out
- Outside mount without Box-out
- Outside mount with 3-sided Box-out is standard

Specialty Styles

BI-FOLD TRACK SYSTEM

- System consists of top and bottom track and quarter-round as standard
- Available in 2½" and 3½" louver sizes
- All wood colors options are available
- Available with Hide-a-Tilt™
- Available with Double Mouse Hole

Configuration Options:

- Outside mount with Box-out
- Outside mount with Stackback
- Inside mount

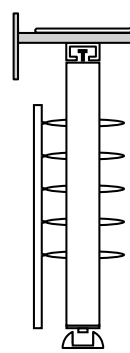
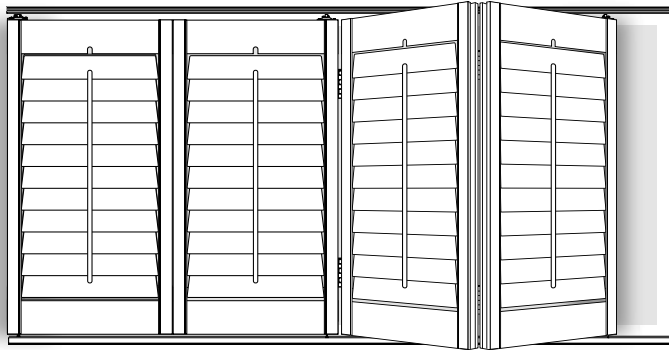

Bottom Track Detail

Installer screws the track to the floor and attaches "quarter-round" up to the face of the track (and along the back of the track, if needed).

Note: Factory does not supply adhesive, trim nails or other fasteners to install quarter-round.

Note: Factory always furnishes bottom track. Installer determines whether bottom track is needed.

OUTSIDE MOUNT NOTES

Width Measurement (using the required Box-out): If no window trim: measure window opening (W-O) size. If window trim: measure outside edge of trim to outside edge of trim.

Factory will add 5" to your overall ordered width. Note: When measuring, add more for bullnose so that frames mount completely on flat surface.

Height Measurement: If no window trim: measure from floor surface to top of window opening. If window trim: measure to top of window trim. **Factory will add 3½" to your overall ordered height.**

Other Measurement Considerations: If there are window moldings, factory can accommodate only up to ½" thick molding when using 3½" louvers and Hide-a-Tilt™.

Track and Header Board: Unit includes track installed to header board. Header is 3½" deep and ¾" thick.

Valances and Returns: One top treatment style is available: standard 2¾" single-bead Valance. Valance returns are included and wrap around the outside of the Box-out (frame). Returns are mitered and are 3⅞" (inside measurement). Refer to the valance options.

Box-out (side frames): Sides frames are required for securing the pivot set of outermost panels. Box-out Frame is ¾" x 3½".

Stackback available: Optional Stackback is available for outside mount bi-fold shutters. Custom Stackback widths are available.

INSIDE MOUNT NOTES

Width Measurement: Order W-O (window opening) and provide net window width. **Factory will make a ½" deduction from the track for proper fit.**

Height Measurement: Order W-O (window opening) and provide net window height. **Factory will make approximately ½" deduction.** Carriers are adjustable.

Other Measurement Considerations: Minimum window depth requirement 3⅝". Standard edge gap (edge of panel to inside of window edge) is ⅜" on both sides of the units.

Track and Header Board: Unit includes track installed to header.

Valances and Returns: One top treatment style is available: standard 2¾" single-bead Valance. No returns are available. Valance ends are not mitered. Refer to the valance options.

Box-out (side frames): Box-out is not available. The pivot set of outermost panels is secured to the inside of window opening.

Stackback not available.

Specialty Styles

BI-FOLD SHUTTER – MINIMUM/MAXIMUM WIDTH ORDER SIZES BY PANEL CONFIGURATION

Panel Configuration	Example of shutter unit configurations using various panel combinations	Outside Mount (with side frame)		Outside Mount with Stackback (with side frame)		Inside Mount	
		Order W-O Size		Order W-O Size		Order W-O Size	
		Minimum Width	Maximum Width	Minimum Width	Maximum Width	Minimum Width	Maximum Width
LL / RR		17"	49"	14"	48"	21"	54"
LLRR / LLLL / RRRR		38"	100"	32"	95"	41"	105"
LLLLRRRR		80"	205"	70"	194"	80"	209"

Wood Bi-fold Minimum and Maximum Height		
	Minimum	Maximum
Outside mount	15 ⁷ / ₈ "	122 ⁷ / ₈ "
Inside mount	17 ⁷ / ₈ "	122 ⁷ / ₈ "

SETTING BRACKET HEIGHT (for outside mount)

For Wall Mount Bi-fold Shutter System Top of Angle Bracket to Floor:

Top of bracket will be 5³/₈" above ordered height.

Note: Side frames determine the mounting height. Bottom edge of side frame is meant to touch the floor surface.

Bi-fold Track System Divider Rail Requirements

- Divider rail required over 84" ordered height
- Tracks wider than 144" will be spliced, header and valance may be spliced over 96" wide.

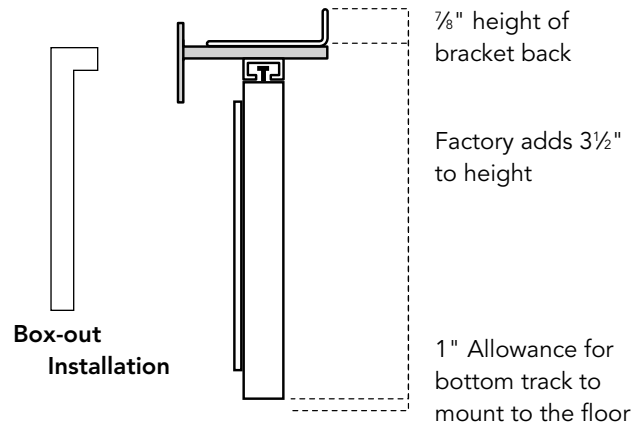

BI-FOLD TRACK SYSTEM PANEL CONFIGURATION OPTIONS

Panel Configurations Must Be Selected From This Chart

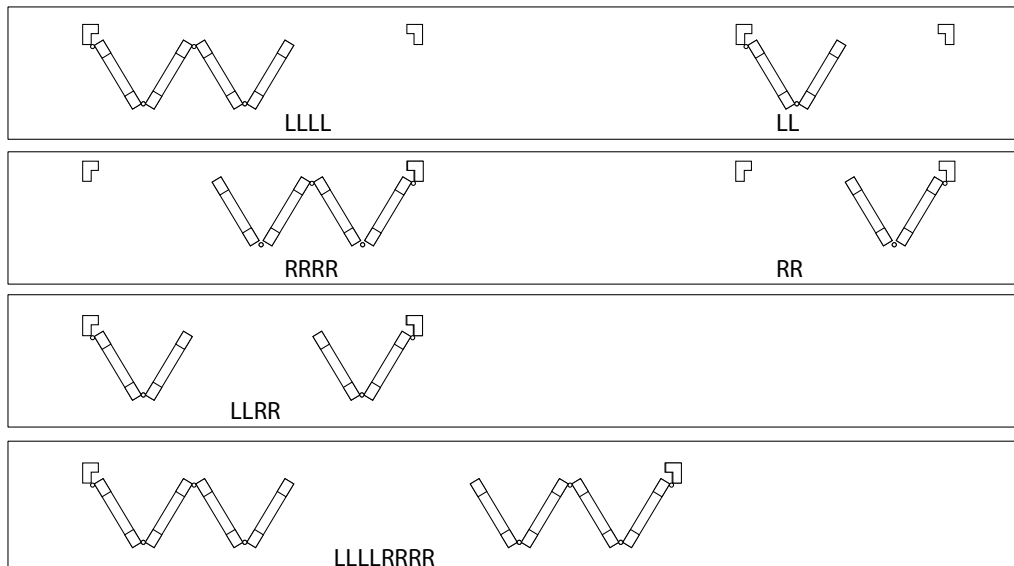

Specialty Styles

BI-FOLD SHUTTERS – STACKBACK

Stackback Option

The Stackback option allows for the shutter panels to clear the window opening, creating an unobstructed view. **Panels made to cover window. Header/track made larger so panels stack off glass.**

Measure only the frame-to-frame area for outside mount with Stackback. Factory will calculate the correct Stackback needed for full Stackback. Custom header also available.

System consists of a double-top track and floor guides

Calculating Approximate Stackback: Factory will add additional width to ordered size for stackback. Amounts vary, depending on the number of panels. See chart below for total (approximate) amount that will be added to the window opening size. This determines the approximate overall unit width.

Configuration Options:

- Outside mount with Box-out

% of Window Opening Size Added for Various Numbers of Panels				
2	3	4	6	8
50%	66%	50%	66%	50%

VALANCE OPTIONS

2³/₈" Standard Valance



Specialty Styles

SIDE LIGHT

Standard Shutter

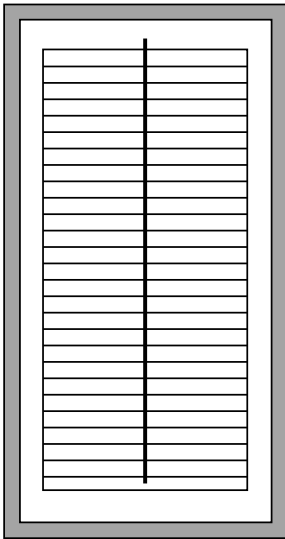

Side Light Shutter

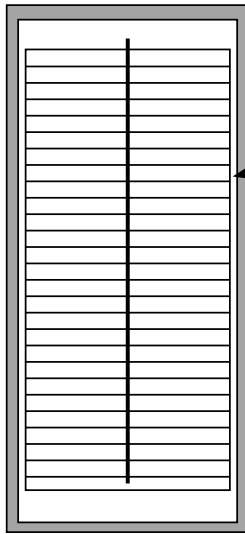

1. 2½" and 3½" louvers only
2. Low profile L-Frame style, similar to sill frame
3. 4-sided frame configuration only
4. Frame-to-frame (F-F) measuring
5. Narrow panel side stile width
6. Left or right panel configurations only
7. Divider rail never required, but is available
8. Buildout is available and is automatically furnished when specifying 3½" louvers. Maximum one layer of buildout. Buildout is attached at the factory.

- Panel side stile = 2"
- L-Frame face width = 1"
- Panel side stile = 1 3/8"
- L-Frame face width = 1/2"

Minimum and Maximum Sizes

Width				Height			
Minimum Order Size (F-F size)	Maximum Order Size (F-F size)	Minimum Finished Panel Width	Maximum Finished Panel Width	Minimum Order Size (F-F size)	Maximum Order Size (F-F size)	Minimum Finished Panel Height	Maximum Finished Panel Height
7 3/16"	13 3/16"	6"	12"	16 1/4"	97 1/4"	15"	96"

Side Light Frame

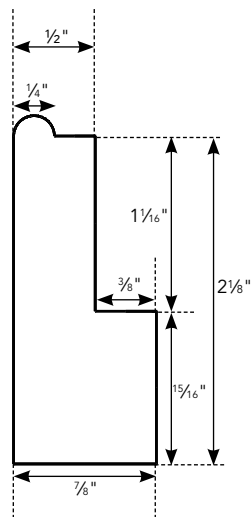

Buildout for Side Light Frame

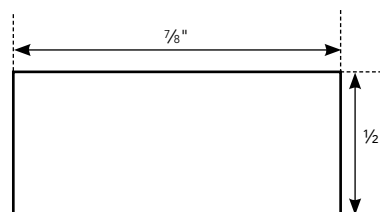

Specialty Styles

BAY WINDOWS

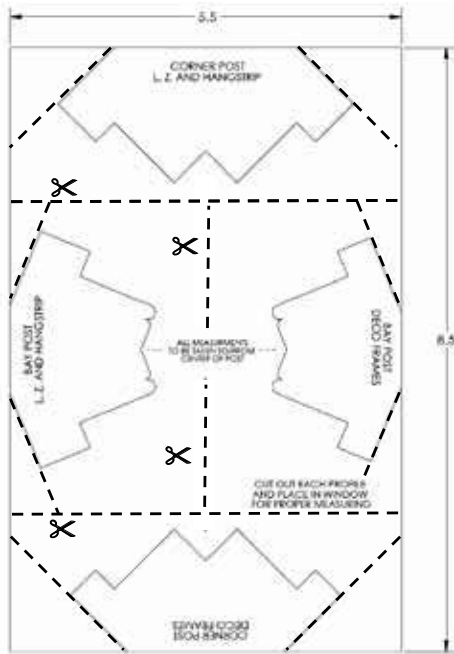

1. 135° (degree) angled bays only
2. Framed configurations offered:
 - 2-sided framed configurations only
 - No 3-sided or 4-sided available
3. Unframed configurations offered:
 - Direct mount and hang strip
4. All frame styles except Tilt Z, Narrow L, Bullnose Z available
5. T-Posts are available (see parameters below)
6. No buildout is available
7. 2½", 3½" and 4½" louvers

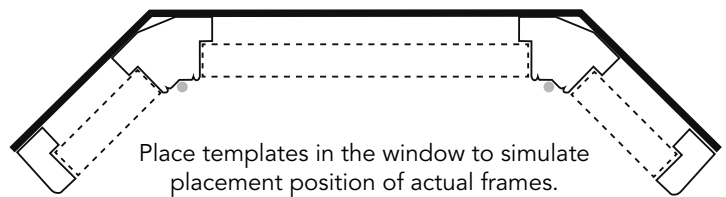

Frame (footprint) template available. Cut out individual pieces for use during measure.

Measuring Tips

1. For direct mount, hang strip and Z-frame: Order WO. Measure from inner edge of window to center of Bay post.
2. For L-Frame and Deco-frame: Order F-F. Measure from outside edge of outer frame to center of Bay post.
3. For center shutter: Measure from center of Bay post to center of Bay post.

Both measure formats use the (front) center of the Bay post as reference points (see small dots on diagram above).

Available Panel Configurations by Window Locations - for Bay Windows

Side Windows: Choose from 1-panel or 2-panel configurations, including ones with one (1) T-Post





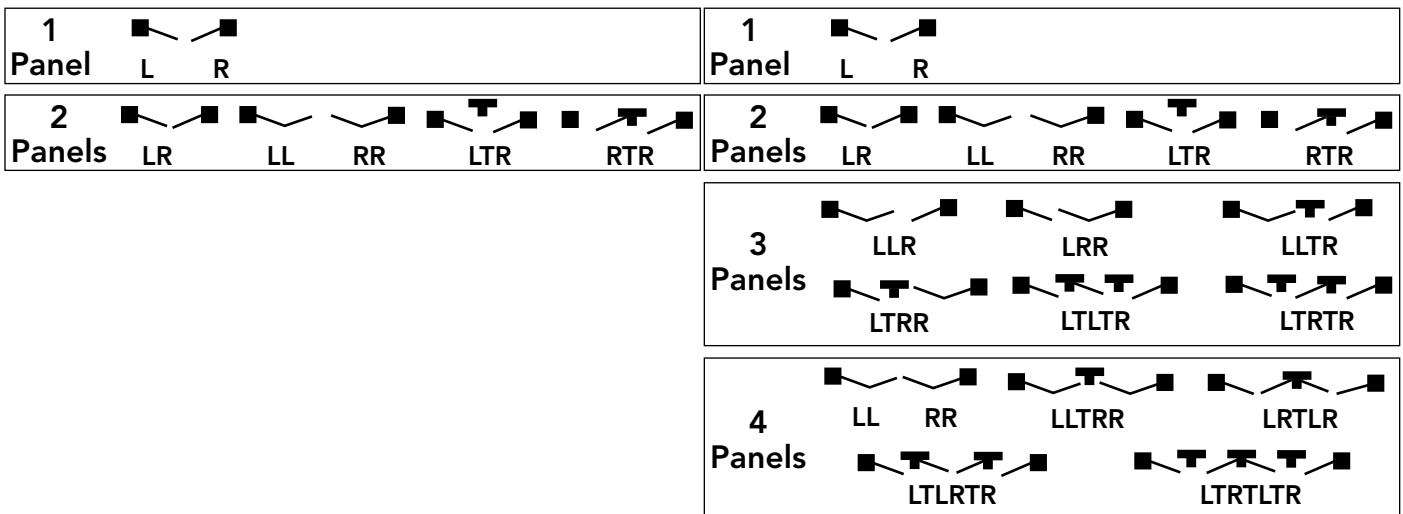



Center Window: Choose from 1-panel, 2-panel, 3-panel and 4-panel configurations, including ones with as many as three (3) T-Posts



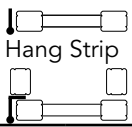
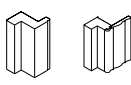

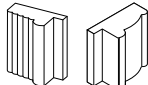
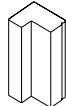

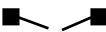
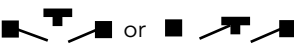





Specialty Styles

BAY WINDOWS

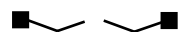
Minimum and Maximum Order Width Sizes by Fold Pattern by Frame Type

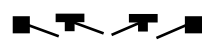
Panel Configurations Available for the Side Windows of the Bay		Direct Mount 		Z-Frames 		3" Deco Frame 		3 1/2" Deco Frame 		L-Frames 	
		Order W-O		Order W-O		Order F-F Size		Order F-F Size		Order F-F Size	
		Min.	Max.	Min.	Max.	Min.	Max.	Min.	Max.	Min.	Max.
1 Panel		9 ³ / ₁₆	36 ¹³ / ₁₆	10 ¹ / ₁₆	37 ⁷ / ₁₆	12 ¹ / ₈	39 ¹ / ₈	12 ¹³ / ₁₆	39 ¹³ / ₁₆	10 ¹³ / ₁₆	37 ¹³ / ₁₆
2 Panel		18 ⁵ / ₁₆	72 ⁵ / ₁₆	19 ⁵ / ₁₆	73 ⁵ / ₁₆	20 ¹³ / ₁₆	74 ¹³ / ₁₆	21 ¹ / ₁₆	75 ¹ / ₁₆	19 ⁵ / ₁₆	73 ⁵ / ₁₆
2 Panel, 1 T-Post		20	74	20 ³ / ₄	73 ³ / ₈	22 ⁵ / ₁₆	75 ³ / ₈	22 ¹³ / ₁₆	75 ¹⁵ / ₁₆	21	74
1 Bi-fold		18 ⁵ / ₁₆	52 ⁵ / ₁₆	19 ⁵ / ₁₆	52 ⁵ / ₁₆	20 ⁵ / ₈	54 ⁵ / ₈	21 ¹ / ₁₆	55 ¹ / ₁₆	19 ⁵ / ₁₆	53 ⁵ / ₁₆

Panel Configurations Available for the Center Window of the Bay, Bay Post-to-Bay Post only (no frame to consider)		Min.	Max.
1 Panel		10 ¹ / ₁₆	37 ⁷ / ₁₆
2 Panel		19 ⁵ / ₁₆	73 ⁵ / ₁₆
2 Panel, 1 T-Post		20 ⁵ / ₈	73 ⁵ / ₈
1 Bi-fold		19 ⁵ / ₁₆	53 ⁵ / ₁₆
1 Panel, 1 Bi-fold		28 ⁵ / ₁₆	89 ⁵ / ₁₆
1 Panel, 1 Bi-fold, 1 T-Post		29 ⁵ / ₈	110 ⁵ / ₈
3 Panel, 2 T-Post		30 ¹³ / ₁₆	111 ¹³ / ₁₆
2 Bi-fold		37 ⁵ / ₁₆	105 ⁵ / ₁₆
2 Bi-fold, 1 T-Post		38 ³ / ₈	106 ³ / ₈
4 Panel, 1 T-Post		38 ³ / ₈	146 ³ / ₈
4 Panel, 2 T-Posts		39 ³ / ₈	147 ³ / ₈
4 Panel, 3 T-Posts		40 ⁵ / ₈	148 ⁵ / ₈

Specialty Styles

CORNER WINDOWS

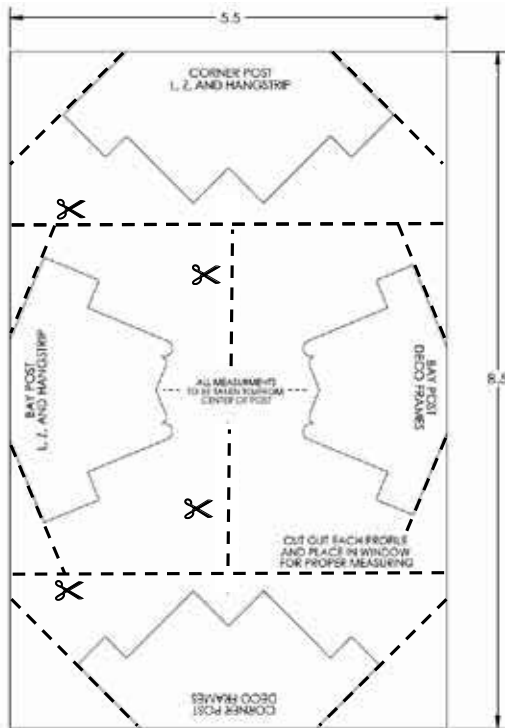

1. 90° (degree) angled corners only
2. Framed configurations offered:
 - 2-sided framed configurations only
3. Unframed configurations offered:
 - Direct mount and hang strip
4. All frame styles except Tilt Z, Bullnose Z and Narrow L available
5. T-Posts are available (see parameters below)
6. No buildout is available
7. 2½", 3½" and 4½" louvers

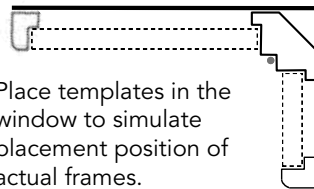

Frame (footprint) template available. Cut out individual pieces for use during measure.

Measuring Tips

1. For direct mount, hang strip and Z-frame: Order WO. Measure from inner edge of window to center of corner post.
2. For L-frame and Deco-frame: Order F-F. Measure from outside edge of outer frame to center of corner post.

Both measure formats use the (front) center of the corner post as reference points (see small dots on diagram above).











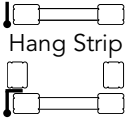
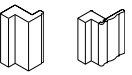

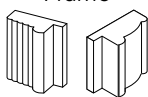
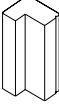

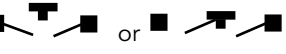
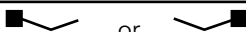

Available Panel Configurations by Window Locations for Corner Windows

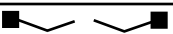
<p>1 Panel</p> <p>L R</p>	<p>5 Panels</p> <p>LTLRRTR LTLTRTR</p> <p>LTLRTRR LTLRTRTR</p>
<p>2 Panels</p> <p>LR LL RR LTR RTR</p>	<p>6 Panels</p> <p>LRTLRTLRL LTLRTRR</p>
<p>3 Panels</p> <p>LLR LRR LLTR LTRR LTLTR LTRTR</p>	<p>8 Panels</p> <p>LRTLRTLRTLRL</p>
<p>4 Panels</p> <p>LL RR LLTRR LRTLRL LTLRTR LRTLTR</p>	

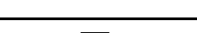
Specialty Styles

CORNER WINDOWS

Minimum and Maximum Order Width Sizes by Fold Pattern by Frame Type

Panel Configurations Available for Both Windows of the Corners		Direct Mount 		Z-Frames 		3" Deco Frame 		3 1/2" Deco Frame 		L-Frames 	
		Order W-O		Order W-O		Order F-F Size		Order F-F Size		Order F-F Size	
		Min.	Max.	Min.	Max.	Min.	Max.	Min.	Max.	Min.	Max.
1 Panel		9 ¹³ / ₁₆	36 ¹³ / ₁₆	10 ¹ / ₁₆	37 ³ / ₁₆	12 ¹ / ₈	39 ³ / ₈	12 ¹³ / ₁₆	39 ¹³ / ₁₆	10 ¹³ / ₁₆	37 ¹³ / ₁₆
2 Panel		18 ⁷ / ₁₆	72 ⁷ / ₁₆	19 ⁹ / ₁₆	73 ³ / ₁₆	20 ¹³ / ₁₆	74 ¹³ / ₁₆	21 ¹ / ₁₆	75 ⁵ / ₁₆	19 ⁹ / ₁₆	73 ³ / ₁₆
2 Panel, 1 T-Post		20	74	20 ³ / ₄	73 ³ / ₈	22 ⁵ / ₁₆	75 ⁵ / ₈	22 ¹³ / ₁₆	75 ¹⁵ / ₁₆	21	74
1 Bi-fold		18 ⁷ / ₁₆	52 ⁷ / ₁₆	19 ⁹ / ₁₆	52 ⁷ / ₁₆	20 ⁷ / ₈	54 ⁷ / ₈	21 ¹ / ₁₆	55 ⁵ / ₁₆	19 ⁹ / ₁₆	53 ³ / ₁₆
1 Panel, 1 Bi-fold		27 ¹ / ₄	88 ¹ / ₄	28 ⁵ / ₈	89 ⁵ / ₈	30 ³ / ₁₆	91 ³ / ₁₆	30 ⁷ / ₈	91 ⁷ / ₈	28 ¹ / ₄	89 ¹ / ₄
1 Panel, 1 Bi-fold, 1 T-Post		28 ¹ / ₄	89 ¹ / ₄	29 ⁵ / ₈	90 ⁵ / ₈	31 ¹ / ₁₆	92 ³ / ₁₆	31 ¹ / ₈	92 ³ / ₈	29 ¹ / ₄	90 ¹ / ₄
3 Panel, 2 T-Post		29	110 ¹ / ₁₆	30 ¹⁵ / ₁₆	111 ¹⁵ / ₁₆	32 ¹ / ₂	113 ¹ / ₂	33 ³ / ₁₆	114 ³ / ₁₆	30 ³ / ₁₆	111 ³ / ₁₆
2 Bi-fold		36 ⁷ / ₁₆	104 ⁷ / ₁₆	37 ¹¹ / ₁₆	105 ¹¹ / ₁₆	39 ³ / ₄	108 ¹⁵ / ₁₆	39 ¹⁵ / ₁₆	108 ¹⁵ / ₁₆	37 ⁷ / ₁₆	105 ⁷ / ₁₆
2 Bi-fold, 1 T-Post		37 ¹ / ₈	105 ¹ / ₈	38 ¹ / ₂	106 ¹ / ₂	40 ¹ / ₁₆	108 ¹ / ₁₆	40 ³ / ₄	108 ³ / ₄	38 ¹ / ₄	106 ¹ / ₄
4 Panel, 1 T-Post		37 ¹ / ₈	145 ¹ / ₈	38 ¹ / ₂	146 ¹ / ₂	40 ¹ / ₁₆	148 ¹ / ₁₆	42 ³ / ₄	148 ³ / ₄	38 ¹ / ₄	146 ¹ / ₄
4 Panel, 2 T-Posts		38 ⁷ / ₁₆	146 ⁷ / ₁₆	39 ¹³ / ₁₆	147 ¹³ / ₁₆	41 ³ / ₈	149 ³ / ₈	42 ¹ / ₁₆	150 ¹ / ₁₆	39 ⁷ / ₁₆	147 ⁷ / ₁₆
4 Panel, 3 T-Posts		39 ³ / ₄	147 ³ / ₄	41 ¹ / ₈	149 ¹ / ₈	42 ¹¹ / ₁₆	150 ¹¹ / ₁₆	43 ³ / ₈	151 ³ / ₈	40 ³ / ₄	148 ³ / ₄
3 Panel, 1 Bi-fold, 2 T-Posts		47 ⁵ / ₈	162 ⁵ / ₈	50 ¹³ / ₁₆	165 ¹³ / ₁₆	55 ³ / ₁₆	170 ³ / ₁₆	57	172	50 ⁵ / ₈	165 ⁵ / ₈
5 Panel, 4 T-Posts		49 ¹⁵ / ₁₆	184 ¹⁵ / ₁₆	53 ¹ / ₈	188 ¹ / ₈	56 ¹ / ₈	192 ¹ / ₈	58 ⁵ / ₁₆	193 ⁵ / ₁₆	52 ¹⁵ / ₁₆	187 ¹⁵ / ₁₆
2 Panel, 2 Bi-fold, 2 T-Posts		56 ³ / ₁₆	178 ³ / ₁₆	57 ¹ / ₁₆	179 ¹ / ₁₆	59 ¹ / ₈	181 ¹ / ₈	59 ¹³ / ₁₆	181 ¹³ / ₁₆	57 ¹³ / ₁₆	179 ¹³ / ₁₆
6 Panel, 2 T-Posts		56 ³ / ₁₆	218 ³ / ₁₆	57 ¹ / ₁₆	219 ¹ / ₁₆	59 ¹ / ₈	221 ¹ / ₈	59 ¹³ / ₁₆	221 ¹³ / ₁₆	57 ¹³ / ₁₆	219 ¹³ / ₁₆
8 Panel, 3 T-Posts		75 ¹ / ₄	291 ¹ / ₄	76 ¹ / ₈	292 ¹ / ₈	78 ³ / ₁₆	294 ³ / ₁₆	78 ¹ / ₈	294 ¹ / ₈	76 ¹ / ₄	292 ¹ / ₄

General Information

DEFINITIONS

Aligning Catch – Concealed magnet and catch plate on back top side of café panels. Used to provide a flush panel alignment.

Astragal – Covers clearance gap between two panels for the purpose of eliminating light gap. Integral to stile.

Bi-fold – Two panels are hinged together to lie flush against the window or wall.

Box-out Frame – Track system frame option that creates an outside mount application consisting of a three-sided frame with or without a decorative valance.

Buildout – Used in conjunction with L-Frames and Deco Frames to move panels away from window, allowing additional clearance for louvers to open.

Bypass Track System – Two or more panels on two overhead track that slide and pass each other.

Café Style Shutters – Shutters cover the lower portion of an opening. They can be made to any height within product specifications. Not recommended for composite as tops are not finished.

Direct Mount – Mounting the shutter panels directly to the window casing.

Divider Rail – A rail that divides the shutter panel into two horizontal sections. It is used to add strength to a tall panel or add a decorative touch.

Double Mouse Hole – Recess on the top and bottom rail allowing for the louvers to be completely closed in either direction.

Guide – Component part used with bypass configurations to lead the panels so that they do not project into the room.

Hang Strip – The mounting frame that is used for inside mount shutter panels.

Inside Mount – A shutter that is mounted on the inside of an opening.

Light Block – Square rail that blocks light between the window sill and the shutter panel, used with direct mount, hang strip, 2-sided frames and 3-sided frames.

Louvers – The movable fins inside the shutter panel.

Mouse Hole – Recess in the top rail of the panel that the lift rod rests in when the louvers are completely closed.

Outside Mount – A shutter that is mounted on the outside of an opening.

Panel – The part of the shutter that consists of a set of louvers, two rails and two stiles.

Rabbet Stile – A special cut on the stiles that allows the panels to overlap. Helps control light penetration between the panels.

Rails – The top and bottom solid portions of a panel that frame the louvers.

Square Window – Diagonal measurements must be within ¼" difference. Windows that are not square will need to have the shutter mounted to the outside of the window opening.

Stackback – Configuration that allows the panels of the bypass or bi-fold track system to completely slide beyond the window opening.

Stile – The vertical portion of the panel frame to which the louvers are anchored.

Tilt Bar – A vertically mounted bar located on the front of the shutter used to open and close the louvers.

T-Post – A vertical post that divides the shutter into two sections (used with wider shutters).

Window Depth – The distance from the surface of the wall to the closest part of the window (examples: latch, crank, frame, etc.).

General Information

WARRANTY

LIMITED LIFETIME WARRANTY

Springs Window Fashions warrants your Shutters will be free from original defects in materials or workmanship for as long as the original purchaser owns the product. Under the Limited Lifetime Warranty, the obligations of Springs Window Fashions are limited to the repair or replacement of parts or product found to be defective. Springs Window Fashions is not responsible for shipping costs or labor costs for measuring and taking the product down or reinstalling the product. If repairs are made under this warranty, the repairs will be made with like or similar parts.

This warranty does not cover conditions or damages caused by accidents, alterations, misuse, exterior use, or failure to follow instructions for measurement, installation, cleaning or maintenance. In addition, normal wear and tear are not covered by the Limited Lifetime Warranty.

Some wood materials may warp in high humidity areas. Springs Window Fashions considers these occurrences normal wear and tear and they are not covered by this warranty.

LIMITATION OF DAMAGES / DISCLAIMER OF WARRANTIES

THIS LIMITED WARRANTY DOES NOT COVER, AND IS INTENDED TO EXCLUDE, ANY AND ALL LIABILITY OF SPRINGS WINDOW FASHIONS, WHETHER UNDER THIS LIMITED WARRANTY OR UNDER ANY WARRANTY IMPLIED BY LAW, FOR ANY INDIRECT OR CONSEQUENTIAL DAMAGES. EXCEPT AS EXPRESSLY PROVIDED IN THIS LIMITED WARRANTY, SPRINGS WINDOW FASHIONS HEREBY DISCLAIMS ALL WARRANTIES TO THE EXTENT PERMITTED BY LAW. ANY IMPLIED WARRANTIES THAT CANNOT BE DISCLAIMED ARE, TO THE EXTENT PERMITTED BY LAW, LIMITED IN DURATION TO FIVE (5) YEARS.

Some states do not allow the exclusion or limitation of incidental or consequential damages, so the foregoing limitation or exclusion may not apply to you. This Limited Warranty gives specific legal rights, and you may also have other rights that vary from state to state. No person is authorized to extend or alter this Limited Warranty.

WARRANTY SERVICE

Warranty claims must be accompanied by the original sales receipt as well as details regarding the nature of the problem, location of the product, etc. If your product is returned, please retain a copy of the shipping information for your records.

To obtain warranty service contact:

Customer Service Center
Springs Window Fashions, LLC
8467 Route 405 Highway South
PO Box 500
Montgomery, PA 17752-0500

You may also email [windowfashions@springswindowfashions.com](mailto>windowfashions@springswindowfashions.com) or call 1-877-675-0089

CARE INSTRUCTIONS

ADJUSTING TENSION SYSTEM

The wood shutters that you have purchased include a built-in tension system to allow for adjustments. If you find that your louvers are too loose or are not functioning to your standards, simply follow these instructions. Open the panels fully; on each side of the panel you will find a tension adjustment screw hole. With a small screwdriver, gently turn the screw 1-2 turns (left to loosen, right to tighten the tension) to your desired resistance level on each side of the panel. Repeat this process for each panel if necessary.

WOOD SHUTTERS

Occasional light vacuuming with a brush attachment should keep shutters clean. For minor soiled areas, clean with warm water using a clean cotton cloth. Dry with a second clean cotton cloth. For more severe soiling, use a mild detergent diluted to a 5% solution with room temperature water. Clean with a cotton cloth. Wipe area with clear water to remove any detergent residue and dry with cotton cloth.

Price Charts and Option Pricing

PRICING CHARTS

Wood Shutter Pricing (base price):

Frame Type	Painted	Stained
Hang Strip, Direct Mount, Tilt-Z (Window Opening)	\$58.00 per sq ft	\$64.80 per sq ft
L-Frame (Frame-to-frame)	\$58.00 per sq ft	\$64.80 per sq ft
Z-Frame (Window Opening).....	\$58.00 per sq ft	\$64.80 per sq ft
Deco Frames (Frame-to-frame)	\$58.00 per sq ft	\$64.80 per sq ft
Bi-fold/Bypass Track Systems.....	\$63.00 per sq ft	\$68.00 per sq ft

Additional Surcharges

Café Shutter with 4-sided frame5%
Hide-a-Tilt™ Bar10%
Bi-fold or Bypass 3-sided Box-out (outside mount only)*15%
Bypass Decorative Valance	No charge
Bi-fold or Bypass Stackback Surcharge*5%
Wood Corner Post & Bay Post Surcharge	\$72
Astragal Stile	No charge
Café Aligning Catch	No charge
Custom Color (flat fee per color per order)	\$99.00 net

*Calculate the overall square footage of the Bypass or Bi-fold panels. Use the overall square footage to calculate the surcharge for the Box-out or Stackback surcharge.

Wood Specialty Surcharges

How to Calculate Specialty Retail Price: Calculate the overall square footage of the specialty, then multiply times the base price of the frame type chosen, and add the surcharge from chart below. Apply dealer discount to the calculated retail price.

ADD SURCHARGE TO SHUTTER PRICE				
	Hang Strip/ Direct Mount	L Frame	Deco Frame	Z-Frame
Sunburst Arches	\$600	\$700	\$750	\$750
Quarter Sunburst Arches	\$600	\$700	\$750	\$750
Arched Panel Shutters	\$600	\$700	\$750	\$750
Angled Panel Shutters	\$600	\$700	\$750	\$750
French Doors**	n/a	\$500	n/a	n/a

**French Doors only available with L-Frame



graberblinds.com